



PED Certified | OHSAS 18001:2007  
| ISO 9001 : 2008 | ISO 14001:2004  
| Govt. Recog. Export House.

**Manufacturer, Exporter, Stockiest, Supplier, Trader for Carbon  
Steel, Stainless Steel, Alloy Steel for Seamless, Welded, ERW,  
LSAW, DSAW, HSAW, HFI, EFW Pipes.**

December 2001

English version

## Water-tube boilers and auxiliary installations - Part 5: Workmanship and construction of pressure parts of the boiler

Chaudières à tubes d'eau et installations auxiliaires - Partie  
5: Fabrication et construction des parties sous pression  
des chaudières

Wasserrohrkessel und Anlagenkomponenten - Teil 5:  
Verarbeitung und Bauausführung für drucktragende  
Kesselteile

This European Standard was approved by CEN on 8 September 2000.

CEN members are bound to comply with the CEN/CENELEC Internal Regulations which stipulate the conditions for giving this European Standard the status of a national standard without any alteration. Up-to-date lists and bibliographical references concerning such national standards may be obtained on application to the Management Centre or to any CEN member.

This European Standard exists in three official versions (English, French, German). A version in any other language made by translation under the responsibility of a CEN member into its own language and notified to the Management Centre has the same status as the official versions.

CEN members are the national standards bodies of Austria, Belgium, Czech Republic, Denmark, Finland, France, Germany, Greece, Iceland, Ireland, Italy, Luxembourg, Netherlands, Norway, Portugal, Spain, Sweden, Switzerland and United Kingdom.



EUROPEAN COMMITTEE FOR STANDARDIZATION  
COMITÉ EUROPÉEN DE NORMALISATION  
EUROPÄISCHES KOMITEE FÜR NORMUNG

Management Centre: rue de Stassart, 36 B-1050 Brussels

## Contents

	Page		Page
Foreword	3	10.3 Pre-heating for welding and thermal cutting	36
1 Scope	4	10.4 Post-weld heat treatment	37
2 Normative references	4	10.5 Heat treatment of production test plates	46
3 Definitions	5	Annex A (normative) Tube bending procedure tests	47
4 Symbols and abbreviations	6	A.1 General	47
5 General	6	A.2 Hot or cold formed bends in tubes with outside diameter $\leq$ 142 mm	47
6 Pressure parts	6	A.3 Cold formed bends in tubes with outside diameter > 142 mm	50
6.1 Drums, headers and similar pressure parts	6	A.4 Hot formed bends in tubes with outside diameter > 142 mm	51
6.2 Material identification	6	Annex B (informative) Welded pressure connections and non-pressure containing attachments	55
6.3 Material marking	7	Annex C (normative) Manufacture of welded tubewalls	59
6.4 Marking during manufacture	7	C.1 General	59
7 Cutting, forming and fabrication tolerances	8	C.2 Methods of manufacture	59
7.1 Cutting of material	8	C.3 Allowable materials	59
7.2 Forming of drums, headers and ends	8	C.4 Manufacturing processes and controls	60
7.3 Forming of tube bends	9	C.5 Welding procedure approvals	61
7.4 Drum and header fabrication tolerances	15	C.6 Production tests	61
8 Welding	18	C.7 Non destructive examination (NDE)	61
8.1 Design and other requirements specific to welding	18	Annex D (normative) Coiled boilers and coiled superheaters	66
8.2 Welding consumables	20	D.1 General	66
8.3 Welding approvals	20	D.2 Special requirements	66
8.4 General production requirements for welding	20	Annex E (normative) Chemical recovery boilers	67
8.5 Repairs to welds	21	E.1 General	67
8.6 Pre-heating	22	E.2 Definition	67
8.7 Post-weld heat treatment	22	E.3 Special requirements for forming of composite tube bends	67
8.8 Welding subsequent to final post-weld heat treatment	23	E.4 Special requirements for manufacture of welded tube walls from composite tubes	68
8.9 Welded joints, connections and production test plates	23	E.5 Material marking	68
8.10 Attachment of non-pressure parts to drums and headers by welding	27	E.6 Flash butt welding	68
8.11 Welding of tubes	27	Annex F (informative) Guidelines for the determination of the competency of boiler manufacturers	69
8.12 Flash butt welding of tubes	29	F.1 General	69
8.13 Welded tube water walls	30	F.2 Responsibility of the user	69
8.14 Arc stud welding	30	F.3 Responsibility of the manufacturer	69
9 Mechanical connections	30	F.4 Requirements concerning manufacturer's competency	69
9.1 General	30	F.5 Manufacturer's competency declaration	69
9.2 Access openings	30	Annex ZA (informative) Clauses of this European Standard addressing essential safety requirements or other provisions of the Pressure Equipment Directive	78
9.3 Branches and nozzles mechanically connected to the main pressure parts	31	Bibliography	78
9.4 Tube connections	32		
9.5 The connection of non-pressure parts to pressure parts	34		
10 Thermal treatment	34		
10.1 General	34		
10.2 Heating cycles and heat treatment(s) associated with plate forming operations	34		

## Foreword

This Document (EN 12952-5:2001) has been prepared by Technical Committee CEN/TC 269 "Shell and water-tube boilers", the secretariat of which is held by DIN.

This European Standard shall be given the status of a national standard, either by publication of an identical text or by endorsement, at the latest by June 2002, and conflicting national standards shall be withdrawn at the latest by June 2002.

This document has been prepared under a mandate given to CEN by the European Commission and the European Free Trade Association, and supports essential safety requirements of the Pressure Equipment Directive (PED)<sup>1</sup>).

For relationship with Pressure Equipment Directive see informative annex ZA, which is an integral Part of this document.

According to the CEN/CENELEC Internal Regulations, the national standards organizations of the following countries are bound to implement this European Standard: Austria, Belgium, Czech Republic, Denmark, Finland, France, Germany, Greece, Iceland, Ireland, Italy, Luxembourg, Netherlands, Norway, Portugal, Spain, Sweden, Switzerland and United Kingdom.

The European Standard series EN 12952 concerning water-tube boilers and auxiliary installations consists of the following Parts:

- Part 1: General
- Part 2: Materials for pressure parts of boilers and accessories
- Part 3: Design and calculation for pressure parts
- Part 4: In-service boiler life expectancy calculations
- Part 5: Workmanship and construction of pressure parts of the boiler
- Part 6: Inspecting during construction, documentation and marking of pressure parts of the boiler
- Part 7: Requirements for equipment for the boiler
- Part 8: Requirements for firing systems for liquid and gaseous fuels for the boiler
- Part 9: Requirements for firing systems for solid fuels for the boiler
- Part 10: Requirements for safeguards against excessive pressure
- Part 11: Requirements for limiting devices and safety circuits of the boiler and accessories
- Part 12: Requirements for boiler feedwater and boiler water quality
- Part 13: Requirements for flue gas cleaning systems
- Part 14: Requirements for flue gas DENOX-systems
- Part 15: Acceptance tests
- Part 16: Requirements for grate and fluidized bed firing systems for solid fuels.

Although these Parts may be obtained separately, it should be recognized that the Parts are inter-dependent. As such, the design and manufacture of boilers requires the application of more than one Part in order for the requirements of the European Standard to be satisfactorily fulfilled.

NOTE Part 4 is not applicable during the design, construction and installation stages.

The annexes A, C, D and E are normative. The annexes B, F and ZA are informative.

---

<sup>1</sup>) Directive 97/23/EC of the European Parliament and of the Council of 29 May 1997 on the approximation of the laws of the Member States concerning pressure equipment; OJEC L181.

## 1 Scope

This Part of the European Standard specifies requirements for the workmanship and construction of water-tube boilers as defined in EN 12952-1.

## 2 Normative references

This European Standard incorporates, by dated or undated reference, provisions from other publications. These normative references are cited at the appropriate places in the text and the publications are listed hereafter. For dated references, subsequent amendments to or revisions of any of these publications apply to this European Standard only when incorporated in it by amendment or revision. For undated references, the latest edition of the publication referred to applies.

EN 287-1, *Approval testing of welders – Fusion welding – Part 1: Steels.*

EN 288-2, *Specification and approval of welding procedures for metallic materials – Part 2: Welding procedure specification for arc welding.*

EN 288-3, *Specification and approval of welding procedures for metallic materials – Part 3: Welding procedure tests for the arc welding of steels.*

EN 288-8, *Specification and approval of welding procedures for metallic materials – Part 8: Approval by a pre-production welding test.*

EN 571-1, *Non destructive testing – Penetrant testing – Part 1: General principles.*

EN 719, *Welding coordination – Tasks and responsibilities.*

EN 729-2, *Quality requirements for welding – Fusion welding of metallic materials – Part 2: Comprehensive quality requirements.*

EN 729-3, *Quality requirements for welding – Fusion welding of metallic materials – Part 3: Standard quality requirements.*

EN 1011-1, *Welding – Recommendations for welding of metallic materials – Part 1: General guidance for arc welding.*

EN 1011-2:1999, *Welding – Recommendations for welding of metallic materials – Part 2: Arc welding of ferritic steels.*

prEN 1092-1:1997, *Flanges and their joints – Circular flanges for pipes, valves, fittings and accessories, PN designated – Part 1: Steel flanges.*

EN 1092-2, *Flanges and their joints – Circular flanges for pipes, valves, fittings and accessories – Part 2: Cast iron flanges.*

prEN 1258:1993, *Welding – Measurement of preheating temperature, interpass temperature and preheat maintenance temperature during welding.*

EN 1290, *Non-destructive examination of welds – Magnetic particle examination of welds.*

EN 1418, *Welding personnel – Approval testing of welding operators for fusion welding and resistance weld setter for fully mechanized and automatic welding of metallic materials.*

EN 1708-1, *Welding – Basic weld joint details in steel – Part 1: Pressurized components*

prEN 1759-1, *Flanges and their joints – Circular flanges for pipes, valves, fittings and accessories, class designated – Part 1: Steel flanges, NPS 1/2 to 24.*

prEN 10002-1:1998, *Metallic materials – Tensile testing – Part 1: Method of test (at ambient temperature).*

EN 10025, *Hot rolled products of non-alloy structural steels – Technical delivery conditions (includes amendment A1:1993).*

EN 10028-1, *Flat products made of steels for pressure purposes – Part 1: General requirements.*

EN 10028-2, *Flat products made of steels for pressure purposes – Part 2: Non alloy and alloy steels with specified elevated temperature properties.*

EN 10045-1, *Metallic materials – Charpy impact test – Part 1: Test method.*

EN 10204, *Metallic products – Types of inspection documents.*

prEN 10216-1:1995, *Seamless steel tubes for pressure purposes – Technical delivery conditions – Part 1: Non-alloy steel tubes with specified room temperature properties.*

prEN 10216-2:1998, *Seamless steel tubes for pressure purposes – Technical delivery conditions – Part 2: Non-alloy and alloy steel tubes with specified elevated temperature properties.*

EN 12952-1, *Water-tube boilers and auxiliary installations– Part 1: General.*

EN 12952-2, *Water-tube boilers and auxiliary installations – Part 2: Materials for pressure parts of boilers and accessories.*

EN 12952-3, *Water-tube boilers and auxiliary installations – Part 3: Design and calculation for pressure parts.*

EN 12952-4, *Water-tube boilers and auxiliary installations – Part 4: In-service boiler life expectancy calculations.*

EN 12952-6, *Water-tube boilers and auxiliary installations – Part 6: Inspection during construction, documentation and marking of pressure parts of the boiler.*

EN 12952-7, *Water-tube boilers and auxiliary installations – Part 7: Requirements for equipment for the boiler.*

EN 25817, *Arc-welded joints in steel – Guidance on quality levels for imperfections (ISO 5817:1992).*

EN 26520, *Classification of imperfections in metallic fusion welds, with explanations (ISO 6520:1982).*

EN ISO 4063, *Welding and allied processes – Nomenclature of processes and reference number (ISO 4063:1998).*

EN ISO 4759-1:1999, *Tolerances for fasteners – Part 1: Bolts, screws, studs and nuts – Product grades A, B and C (ISO/DIS 4759-1:1999).*

EN ISO 9692-2, *Welding and allied processes – Joint preparation – Part 2: Submerged arc welding of steels (ISO 9692-2:1998).*

EN ISO 14555, *Welding – Arc stud welding of metallic materials (ISO 14555:1998).*

ISO 8501-1, *Preparation of steel substrates before application of paints and related products – Visual assessment of surface cleanliness – Part 1: Rust grades and preparation grades of uncoated steel substrates and of steel substrates after overall removal of previous coatings.*

CR ISO 15608, *Welding – Guideless for a metallic material grouping system (ISO/TR 15608:2000).*

### 3 Definitions

For the purposes of this standard the definitions given in EN 12952-1 and the following apply.

#### 3.1

##### cold forming

for ferritic steels, it is forming at temperatures below the maximum permissible temperature for post-weld heat treatment in accordance with table 10.4-1. Cold forming for austenitic materials is forming at temperatures below 300 °C.

### 3.2

#### hotforming

for ferritic steels, it is forming at temperatures at or above the maximum permissible temperature for post-weld heat treatment in accordance with table 10.4-1.

## 4 Symbols and abbreviations

For the purposes of this European Standard, the symbols given in table 4 – 1 of EN 12952-1 shall apply. Throughout this European Standard, additional terminology and symbols have been included, where necessary, to meet the requirements of the specific text concerned. It should also be noted that in some clauses the same additional symbol is used in different equations to represent different terms. However, in all such cases, the special meaning of each symbol is indicated for each equation.

## 5 General

Water-tube boilers shall be manufactured and assembled in accordance with approved drawings, procedures and specifications and good engineering practice.

The workshops and sites associated with the construction of water-tube boilers shall be properly equipped and have suitable provisions for all the inspection and testing specified in EN 12952-6. The relevant manufacturing procedures shall be adequate and manufacturing personnel shall be competent and properly qualified for their assigned tasks. The procedures for the approval of welding and NDE personnel are given respectively in clauses 7 and 9.2 of EN 12952-6.

Appropriate records of manufacturing operations shall be maintained.

## 6 Pressure parts

### 6.1 Drums, headers and similar pressure parts

6.1.1 Drums, headers and similar pressure parts shall be constructed from tubes, forgings, plates or castings. Drums and headers shall be in a suitably clean condition, both internally and externally, to enable proper visual inspection of the surface to be carried out before drilling of holes for tube stubs, branches, etc. and before welding of any permanent connections.

6.1.2 The ends of forged or other seamless steel tube headers shall be carried out by any one of the following methods:

- a) forging or spinning;
- b) welding in accordance with clause 8, see also figure 10.3-1 of EN 12952-3;
- c) bolted flanges in accordance with the relevant European Standards e.g prEN 1092-1 or prEN 1759-1.

Bolted flanges in accordance with c) shall not be used where the bolts would be exposed to gases of combustion.

6.1.3 Header ends shall be forged or machined from steel of a grade compatible with the bodies of the headers and profiled as shown in figure 10.3-1 of EN 12952-3.

### 6.2 Material identification

The manufacturer shall maintain a system of material identification for all pressure parts and drum lifting lugs.

The system shall be such that material used in major pressure parts (drums, tubes for header shells with  $d_o > 142$  mm) can be traced back to its origin. The identification of tubes which are not used for header shells and tubes for header shells with  $d_o \leq 142$  mm shall be controlled by a system which permits positive identification of cast, on receipt into the manufacturer's works and maintenance of the material type identification throughout manufacturing operations by marking.

### 6.3 Material marking

6.3.1 The marking of materials shall be maintained throughout the process of manufacture. If original markings are discarded or parts without markings could be created by dividing up parts during the course of manufacture, markings shall be transferred, normally before fabrication.

Appropriate measures shall be taken to ensure that there is no possibility of confusion in the transfer of markings.

6.3.2 Marking transfer shall be performed by the manufacturer's nominated representative(s) except for materials requiring certificate (3.1.A/3.1.C) to EN 10204 not classified as small parts.

In the case of materials for which a certificate 3.1.A to EN 10204 is required, the markings shall be transferred in accordance with the requirements of EN 12952-6.

NOTE This does not apply to small parts which are those made from certified products, such as nipples, nozzles, flanges, compensating rings, with outside diameters equal to or less than 142 mm.

6.3.3 In general, material marking should be done by hard stamping using a low stress type metal stamp or etching.

NOTE Other marking methods may be used if the manufacturer can ensure that their use will not impair the safety of the boiler.

6.3.4 For welded non-pressure parts, marking need only be transferred if the identification of materials is not evident from the drawing or parts list.

6.3.5 Bolts and nuts for pressure purposes shall be marked with the manufacturer's landmark and property class symbol, or the steel grade code number in accordance with EN ISO 4759-1.

### 6.4 Marking during manufacture

#### 6.4.1 Temporary marking

Temporary marks for the purpose of identification during manufacture e.g. parts numbers, welder numbers, radiograph numbers etc. shall be made by any one, or a combination, of the following methods:

- a) painting or pen, provided they are compatible with the material being marked;
- b) vibro etching or other etching tool;
- c) metal stamps of the low stress type.

#### 6.4.2 Permanent marking

Permanent marks complying with the requirements of 6.2 shall be made by any one, or a combination, of the following methods:

- a) vibro etching or other etching tools;
- b) metal stamps of the low stress type;
- c) stamped data plates welded directly to the component using an approved welding procedure specification.

EN 12952-5:2001 (E)

#### 6.4.3 Tube bends

Metal stamping shall not be permitted on the curved area of tube bends.

#### 6.4.4 Location drawings

Location drawings may be provided in the case of welders marks, radiographs etc.

## 7 Cutting, forming and fabrication tolerances

### 7.1 Cutting of material

7.1.1 Steel shall be cut by thermal means, shearing, sawing, machining or a combination of these methods. Thermal cutting may necessitate the use of preheating, depending on the type of steel and the thickness in question, which shall be applied in accordance with 10.3.3. It is recognized that the cold worked zone resulting from the shearing process need not be eliminated before welding if this zone will be fused during welding.

7.1.2 Any material damaged metallurgically in the process of cutting to size or forming the edge or end preparation shall be removed by machining, grinding, chipping or thermal-cutting back to sound metal.

Surfaces that have been thermally cut shall be cut back by machining or grinding so as to remove all burnt metal, harmful notches, slag and scale, but slight discoloration of machine thermally cut edges on mild steel shall not be regarded as detrimental. If alloy steels are prepared by thermal cutting, the surface shall be dressed back by grinding or machining for a distance of at least 1,5 mm, unless it can be shown that the material has not been damaged by the cutting process.

NOTE These requirements for dressing do not apply to surfaces that are prepared for electro-slag welding, where a thermally cut surface is generally acceptable without further treatment.

After the edges of the material have been prepared for welding, they shall be visually examined for flaws, cracks, laminations, slag inclusions or other defects before further work is carried out. Any weld repairs that are required to materials damaged as a result of thermal cutting shall be to an approved welding procedure specification.

### 7.2 Forming of drums, headers and ends

#### 7.2.1 General

Drums, headers and ends shall be rolled or pressed from plate, solid forged, drawn or extruded, or made by a combination of these processes. Components made by a forging, drawing or extrusion process shall be produced in accordance with the forgemasters specification, as agreed with the boiler manufacturer.

Components formed from ferritic steel plate shall be heat treated in accordance with 10.2.2 to 10.2.4 inclusive. The heating associated with forming operations and the heat treatment requirements after forming are given in 10.2.

The forming requirements applicable to austenitic steel plate are the subject of development. In the meantime the methods used shall be in accordance with the manufacturer's own proven procedure which shall ensure that, by their use, the safety of the boiler is not impaired.

#### 7.2.2 Drum and header shells

Shell plates shall be formed, either hot or cold, to ensure compliance with the tolerances specified in 7.4. Each shell plate shall be formed to the correct contour up to the extreme edges of the plate. The bending or pressing shall be done entirely by machine. The definitions of hot and cold forming are given in 3.1 and 3.2.

Local heating and hammering shall not be employed.

#### 7.2.3 Ends

Dishing and peripheral flanging, either hot or cold, shall be carried out to ensure compliance with the tolerances specified in 7.4. The operations shall be performed by machine. Sectional flanging shall not be employed.

#### 7.2.4 Plates welded prior to hot or cold forming

Where practicable, shells and ends shall be rolled or pressed from one piece of plate. Where this is impracticable, butt welding of plate, prior to forming shall be permitted, provided that the welded joints are non-destructively examined after forming in accordance with the requirements of EN 12952-6, and a welding procedure qualification test has been performed to EN 288-3 taking into account any heat treatment cycles involved. A production test plate as specified in 10.2.5, shall be provided.

#### 7.2.5 Extruded openings in headers

Extruded openings in headers shall have a fillet with a radius not less than the thickness of the neck of the extrusion as shown in figure B-2 of annex B.

### 7.3 Forming of tube bends

#### 7.3.1 General

Tubes which are bent hot or cold shall conform to 7.3.2 to 7.3.12.

Tube bends which do not conform to these requirements may be acceptable if the manufacturer can ensure their use will not impair the safety of the boiler.

NOTE Annex A requires procedure tests to be carried out on tube bends. Attention is drawn to the fact that not all the combinations of materials and bending processes permitted, and the associated thermal treatments nominated in table 7.3-2, will satisfy the requirements for the procedure test given in 7.3.2 to 7.3.13 and annex A.

The manufacturer should ensure that any combination of material, bending process and the chosen bend geometry will produce bends that satisfy the requirements of 7.3. If a chosen bend geometry is found not to comply with the requirements of 7.3, the manufacturer should adjust the design to enable the requirements to be met.

#### 7.3.2 Tube bending procedure test

It shall be demonstrated by means of a tube bending procedure test (see annex A) that tubes can be satisfactorily bent to the requirements of 7.3.1. The tests shall be performed to represent combinations of tube sizes, materials and bend radii which demonstrate the adequacy of the bending method chosen. The range and scope of the qualification of tube bends resulting from these procedure tests are also given in annex A. The results from the bending procedure tests shall be documented and used as a basis for all future tube bends falling within the scope of the combinations tested.

When specific pre-production test bends are manufactured in accordance with table 7.3-1 and which conform to the requirements of 7.3.1 the resulting documented data shall serve as qualification for subsequent production runs and may be considered to satisfy the requirements of annex A.

NOTE Documented evidence of previous satisfactory tube bending procedure tests may be accepted as fulfilling these requirements.

#### 7.3.3 Requirements for dimensional testing

Thinning at the bend extrados, thickening at the bend intrados (where required) and departure from circularity limits shall be demonstrated by the methods given in table 7.3-1.

NOTE This test relates to the forming of tubes for conventional water-tube boilers. For the special case of coiled boilers and coiled superheaters, see annex D.

Table 7.3.1 — Requirements for dimensional testing of a production run of tube bends

Tube size - Nominal outside diameter $d_o$ mm	Testing during a production run of tube bends
$d_o \leq 80$	a) Measure non-destructively 2 % of the production run, including the first bend, for thinning and departure from circularity $u$ . b) Additionally, where $r_b/d_o < 1,3$ , a sample test bend is required before production commences.
$80 < d_o \leq 142$	a) Measure non-destructively 2 % of the production run, including the first bend, for thinning, thickening (where practicable) and the departure from circularity $u$ . b) Additionally, where $r_b/d_o < 1,3$ a sample test bend is required before production commences.
$d_o > 142$	Measure all bends for thinning, thickening and the departure from circularity $u$ .
<p>NOTE 1 A sample test bend consists of the sectioning and measuring of a trial bend to establish the maximum thinning, thickening (where practicable), and the maximum departure from circularity. The measured values are to be checked against the requirements given in 7.3.4, 7.3.5 and 7.3.7 respectively.</p> <p>NOTE 2 A production run is defined as a series of tubes of the same size and material being bent on a specific machine within the same machine set-up.</p> <p>NOTE 3 The departure from circularity <math>u</math> is to be measured at the apex of the bend.</p> <p>NOTE 4 The radius of the bend <math>r_b</math> measured to the centre-line of the tube.</p> <p>NOTE 5 The outside diameter <math>d_o</math> of the tube measured on the straight.</p> <p>NOTE 6 This table does not apply to Coil type boilers (see annex D).</p>	

### 7.3.4 Thinning at the tube bend extrados for tubes of nominal outside diameter 142 mm and below

The thickness at any point after bending shall not be less than that given by equation:

$$e_{\text{ext}} = e_{\text{act}} \times \frac{2 r_b/d_o + 0,5}{2 r_b/d_o + 1} \quad (7.3-1)$$

where

$e_{\text{ext}}$  is the required minimum thickness at the extrados, in mm;

$e_{\text{act}}$  is the nominal thickness of the supplied tube minus the supplier's maximum negative thickness tolerance, in mm;

$r_b$  is the radius of the bend measured to the centre-line of the tube in mm;

$d_o$  is the nominal outside diameter of the tube, in mm.

When the measured value on the tube bend is less than  $e_{\text{ext}}$  reference shall be made to the minimum calculated thickness given in 11.3 of EN 12952-3.

The thinning on the extrados of bends formed in two stages i.e. hot formed after initial hot or cold bending, shall not exceed 30 % of the thickness of the straight tube local to the bend as measured during a procedure test.

### 7.3.5 Thickening at the tube bend intrados for tubes of nominal outside diameter above 80 mm up to and including 142 mm

The thickness at any point after bending shall not be less than that given by equation:

$$e_{\text{int}} = e_{\text{act}} \times \frac{2 r_b / d_o - 0,5}{2 r_b / d_o - 1} \quad (7.3-2)$$

where

$e_{\text{int}}$  is the required minimum thickness at the intrados, in mm;

$e_{\text{act}}$  is the nominal thickness of the supplied tube minus the supplier's maximum negative thickness tolerance, in mm;

$r_b$  is the radius of the bend measured to the centre-line of the tube, in mm;

$d_o$  is the nominal outside diameter of the tube, in mm.

When the measured value on the tube bend is less than  $e_{\text{int}}$  reference shall be made to the minimum calculated thickness given in 11.3 of EN 12952-3.

### 7.3.6 Thinning/thickening at the tube bend extrados/intrados for tubes of nominal outside diameter greater than 142 mm

For tubes above 142 mm diameter comparison shall be made directly with the calculated thickness given in 11.3 of EN 12952-3. The calculated thickness shall be stated on the drawing.

### 7.3.7 Departure from circularity of the tube bends

The departure from circularity of tube bends shall be calculated from the equation:

$$u = 2 \times \frac{(\hat{d}_o - \check{d}_o)}{(\hat{d}_o + \check{d}_o)} \times 100 \% \quad (7.3-3)$$

where

$u$  is the departure from circularity, in %;

$\hat{d}_o$  is the maximum outside diameter measured at the tube bend apex, in mm;

$\check{d}_o$  is the minimum outside diameter measured at the same cross-section as  $\hat{d}_o$ , in mm.

The permitted departure from circularity shall be within the limits given in figures 7.3-1 and 7.3-2.

- The departure from circularity of tube bends, which are bent in a single continuous operation, shall not exceed the limits shown in figure 7.3-1.
- The departure from circularity of tube bends on tubes not exceeding 80 mm nominal outside diameter, which are bent by a double operation i.e. hot pressed after the primary bending operation then post-bend heat treated in accordance with table 7.3-2, shall not exceed the limits shown in figure 7.3-2.

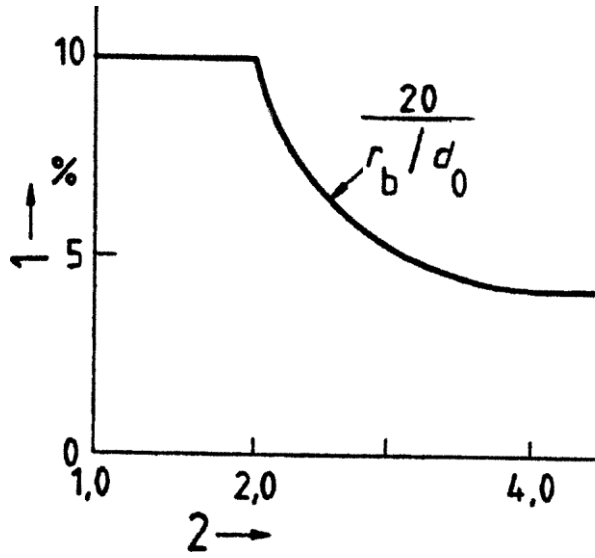

- key  
 1 Departure from circularity  $u$   
 2 Ratio  $r_b/d_0$

Figure 7.3-1 — Limits of departure from circularity for single operation bending

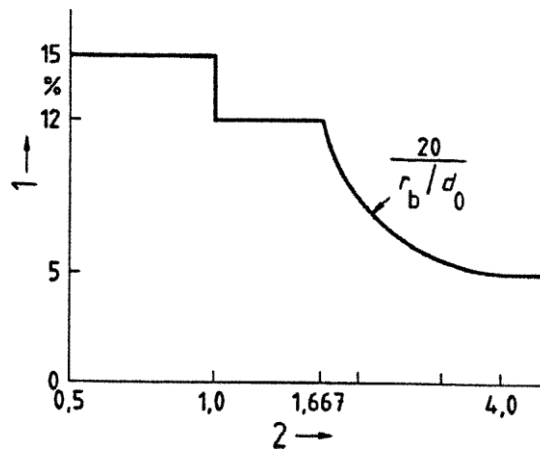

- key  
 1 Departure from circularity  $u$   
 2 Ratio  $r_b/d_0$

Figure 7.3-2 — Limits of departure from circularity for double operation bending

### 7.3.8 Post-bend heat treatment of tube bends

The post-bend heat treatment (PBHT) of hot or cold formed bends shall be in accordance with the following rules:

- All hot formed tube bends and cold formed bends requiring heat treatment after bending, including bends hot formed after cold bending, shall be heat treated in accordance with the requirements of 7.3.9 except as defined in b) or e) below.
- Hot formed tube bends in steel group 1, with outside diameters of 80 mm or less, need not receive a post-bend heat treatment if it can be demonstrated that the bending operation was completed within the normalizing range as defined in the relevant base material standard, or data sheet, as appropriate.
- All cold bent tube bends with thinning greater than 25 % as measured in the procedure test, shall be heat treated in accordance with the requirements of 7.3.9.
- PBHT of cold formed tube bends in accordance with table 7.3-2 shall be carried out in accordance with the requirements of 7.3.9.

Table 7.3-2 — Post-bend heat treatment applicable to cold formed tube bends

$d_o$ mm	Bend ratio	Heat treatment
$d_o > 142$	$r_b/d_o > 2,5$	No post-bend heat treatment required
$d_o > 142$	$r_b/d_o \leq 2,5$	Stress relieve
$d_o \leq 142$	$r_b/d_o > 1,3$	No post-bend heat treatment required
$d_o \leq 142$	$r_b/d_o \leq 1,3$	Stress relieve

- Post-bend heat treatment may be waived if it can be demonstrated by a suitable procedure test, that heat treatment shall not be required.
- For hot formed bends local post bend heat treatment of the tube bend shall not be acceptable. Any post-bend heat treatment involving normalising shall encompass the bend and adjacent straight lengths of tube.

### 7.3.9 Post-bend heat treatment requirements

#### 7.3.9.1 Ferritic tubing

With the exception of those cases in accordance with 7.3.8, all tube bends shall receive a post-bending heat treatment as follows:

#### a) Hot formed bends

All hot formed bends, including bends which have been hot pressed after cold forming, shall be heat treated in order to restore the material properties to their optimum condition. The post bending heat treatment applied shall be in accordance with the requirements given in the relevant base material standard, or data sheet, as appropriate.

For hot formed bends local post bend heat treatment of the tube bend is not acceptable. Any post bend heat treatment involving normalising operation shall encompass the bend and adjacent straight lengths of tube.

#### b) Cold formed bends

When a stress relief heat treatment is specified in the case of normalized and tempered or quenched and tempered materials, the requirements for tempering given in the relevant base material standard, or data sheet, shall be followed as appropriate.

When a stress relief heat treatment is specified in the case of normalized only materials, the requirements for post-weld heat treatment given in tables 10.4-1 and 10.4-2, shall be followed.

Other stress relief heat treatment methods may be used if it can be demonstrated to be adequate by means of the procedure test.

7.3.9.2 Austenitic tubing

Post-bending heat treatment will normally not be required for cold bent austenitic tubing.

Any post bending heat treatment requirements for hot bent austenitic tubing shall be in accordance with the manufacturer's own proven procedure which shall ensure that, by their use, the safety of the boiler is not impaired.

7.3.10 Ripples on the intrados of tube bends

7.3.10.1 General

Ripples are multiple wave like undulations on the intrados of tube bends, see figure 7.3-3.

Deviations from the nominal bend profile are local isolated deviations from a smooth normal profile of the intrados of the bend, e.g. irregularities sometimes found at the commencement of mandrel assisted bends in small diameter tubes.

7.3.10.2 Acceptance standards

- a) In tubes up to and including 80 mm nominal outside diameter, ripples shall not be acceptable. Deviations from nominal bend profile may be accepted provided the departure from circularity at the peak and trough of the deviation meets the requirements of 7.3.7.
- b) For tubes above 80 mm nominal outside diameter up to and including 142 mm nominal outside diameter, ripples and deviations from the nominal bend profile shall not be permitted.
- c) Tubes with nominal outside diameters greater than 142 mm shall be permitted to contain ripples on the intrados of the bend within the limits shown in figure 7.3-3, provided they have a smooth profile and blend into the surface of the bend. Deviations from the nominal bend profile shall not be permitted.

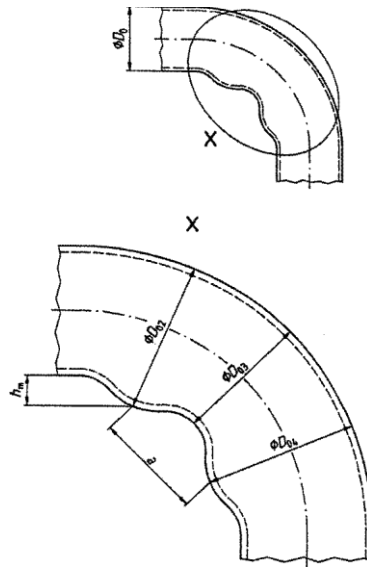

$d_0, d_{02}, d_{03}, d_{04}, \dots$  etc is the actual outside diameter of the tube at the position being measured.

NOTE For clarity, the ripples have been exaggerated.

Figure 7.3-3 — Ripples on tube bends

For such ripples to be acceptable, both the following conditions shall be satisfied:

$$\text{Amplitude of the ripples } h_m = 0,5 (d_{02} + d_{04}) - d_{03} < 0,03 d_0 \quad (7.3-4)$$

$$\text{Wave pitch } a > 12 h_m \quad (7.3-5)$$

#### 7.3.11 The surface of tube bends

The surface of tube bends shall be free of defects such as cracks, indentions, laps and scabs. Surface defects may be removed by grinding. In such cases the resulting thickness shall not be less than the minimum calculated thickness given in 11.3 of EN 12952-3.

The surface of the tube bend shall be such as to permit effective visual examination.

Areas of the tube bend which have been ground to remove defects shall be examined by surface flaw detection methods to ensure that complete removal of the defect has been effected.

Repairs to the tube surface by welding are generally not permitted. However, in special cases of tubes of 142 mm nominal outside diameter and above, such repairs may be acceptable, when supported by an approved welding procedure specification and taking into account the following:

- a) the extent of the zone to be repaired;
- b) the grade of the material involved;
- c) the diameter and thickness of the bend;
- d) the heat treatment conditions involved;
- e) the operating temperature of the tube bend.

#### 7.3.12 Gang bending of tube panels

The tube bends produced by the gang bending method shall conform, in all respects, with the requirements of tubes bent singly, see A.2.4.7.

The departure from circularity shall be measured during production on the two outermost tubes of the panel. The results shall be compared with the requirements of 7.3.7. For practical reasons,  $\hat{d}_o$  in the equation (7.3-3) should be replaced by the outside diameter of the tube measured in the straight.

#### 7.3.13 Bending of composite materials tubing

The bending procedures adopted for metallurgically bonded composite materials tubing shall be in accordance with the requirements of 7.3. In addition, any special requirements recommended by the tube manufacturer shall be taken into consideration.

### 7.4 Drum and header fabrication tolerances

#### 7.4.1 Assembly tolerances for shells fabricated from plate and ends to shells

##### 7.4.1.1 General

Middle line and surface alignment tolerances shall be permitted as follows, where  $e_a$  is the actual thickness of the thinnest plate at the joint.

## 7.4.1.2 Middle line alignment tolerances

The root faces of the weld preparations shall be aligned within the tolerances permitted by the welding procedure specification and the components shall be aligned as indicated on the drawings within the following tolerances.

- a) For longitudinal joints in cylindrical components, the middle lines of adjacent plates shall be aligned within the tolerances given in the table 7.4-1.

Table 7.4-1 — Offset of middle lines for longitudinal joints in cylindrical components

Plate thickness $e_a$ mm	Offset of middle lines mm
$e_a \leq 10$	$\leq 1$
$10 < e_a \leq 50$	$\leq e_a/10$ or 3, whichever is the smaller
$e_a > 50$	$\leq e_a/16$ or 10, whichever is the smaller

- b) For circumferential joints, the middle lines of adjacent plates shall be aligned within the tolerances given in table 7.4-2.

Table 7.4-2 — Offset of middle lines for circumferential joints in cylindrical components

Plate thickness $e_a$ mm	Offset of middle lines mm
$e_a \leq 10$	$\leq 1$
$10 < e_a \leq 60$	$\leq 10\%$ of thickness of thinner part plus 1, or 6, whichever is the smaller
$e_a > 60$	$\leq 10\%$ of the thickness of thinner part

## 7.4.1.3 Surface alignment tolerances

The alignment at the surface of adjacent plates shall either

- a) not exceed the maximum tolerances:

- 1) For longitudinal joints given in table 7.4-3

Table 7.4-3 — Offset of surfaces of longitudinal joints in cylindrical components

Plate thickness $e_a$ mm	Offset of surfaces mm
$e_a \leq 12$	$\leq e_a/4$
$12 < e_a \leq 50$	$\leq 3$
$e_a > 50$	$\leq e_a/16$ or 10, whichever is the smaller

2) For circumferential joints given in table 7.4-4

Table 7.4-4 — Offset of surfaces of circumferential joints in cylindrical components

Plate thickness $e_a$ mm	Offset of surfaces mm
$e_a \leq 20$	$\leq e_a/4$
$20 < e_a \leq 40$	$\leq 5$
$e_a > 40$	$\leq e_a/8$ or 20, whichever is smaller.

or

- b) if the maximum alignment tolerances in a) are exceeded, they may be reduced by tapering the surface(s) at a slope no steeper than that permitted by 8.1.1.1b) or 10.2.1.4 of EN 12952-3, as appropriate, over a width that includes the width of the weld.

Either of the following methods of tapering shall be permitted:

- 1) building up the surface of the thinner plate with added weld metal in accordance with an approved welding procedure specification to provide the required taper; or
- 2) tapering one or both of the thicker plate surfaces.

The tapering method 2) shall not be permitted if it would reduce the plate thickness below the specified minimum for the component at the location in question.

## 7.4.2 Finished tolerances for shells

### 7.4.2.1 Tolerance on diameter

The diameter of a drum shall not deviate from the nominal diameter by more than  $\pm 1\%$ .

### 7.4.2.2 Circularity (out-of-roundness)

The difference between the maximum and minimum internal diameters at any one cross section shall not exceed 1% of the nominal internal diameter. If the drum is made of plates of unequal thicknesses, the measurements shall be corrected for plate thicknesses, as they may apply, to determine the diameters at the middle line of the plates.

Irregularities in profile, checked using a template embracing an arc of  $20^\circ$ , shall not exceed 3 mm plus 5% of the minimum plate thickness. A 25% increase in the maximum value shall be permitted if the length of the irregularity does not exceed one-quarter of the length of the shell ring with a maximum of 1 000 mm.

There shall be no flats at welded seams and any local departure from circularity shall be gradual. Small departures from circularity may be rectified by cold rolling. However, any non-destructive examination as required by EN 12952-6 shall be carried out after the cold rolling operation.

### 7.4.2.3 Straightness

The maximum deviation of the complete shell from a straight line shall not exceed 0,3% of the total cylindrical length. Measurements shall be made to the surface of the parent plate and not to a weld, fitting or other raised part.

EN 12952-5:2001 (E)

#### 7.4.3 Finished tolerances for ends

##### 7.4.3.1 Tolerances on diameters

The requirements of 7.4.2.1 shall apply.

##### 7.4.3.2 Circularity (out-of-roundness)

The requirements of 7.4.2.2 shall apply.

##### 7.4.3.3 Thickness

Variations in thickness (thinning) arising during manufacture shall be gradual. In no case shall the thickness of the end be less than the design thickness given in 10.2 of EN 12952-3.

##### 7.4.3.4 Profile

The depth of dishing, measured from the plane passing through the point where the straight flange joins the knuckle radius, shall in no case be less than the theoretical depth, nor shall this depth be exceeded by more than 1,25 % of the diameter, for diameters of ends up to and including 3000 mm. Variations of the profile shall not be abrupt, but shall merge gradually into the specified shape. The knuckle radius shall not be less than specified, and shall have common tangents with both the straight flange and the dished profile, at each junction.

## 8 Welding

### 8.1 Design and other requirements specific to welding

8.1.1 The following special requirements specific to welding shall be considered before any manufacturing is commenced.

NOTE General guidance on welding of ferritic steels is given in EN 1011-1 and prEN 1011-2 which may be used to supplement the welding requirements of this European Standard.

8.1.2 The selection of materials for the pressure parts, and for any attachments to be made to them, shall be such that any welding operations which are to be carried out will not render the component unfit for its intended duty.

The selection of welding consumables shall be such as to ensure the cross-weld strength required by the design is achieved. The effects of post-weld heat treatment on the completed joint as given in 8.7, shall also be taken into consideration.

8.1.3 The boiler manufacturer shall supply, on request, fully dimensioned detailed drawings showing the construction of all pressure parts to be welded and copies of all associated welding procedure specifications prepared in accordance with clause 6 of EN 12952-6.

The dimensioned drawings of main pressure parts shall include the location of all main joints and attachments to be made to the components, clearly showing details of the main joint weld preparations, all attachment welds, and their location relative to the longitudinal and circumferential joints and openings.

8.1.4 Welding of the joints of the component parts of a water-tube boiler shall only be undertaken when the following conditions are satisfied:

- a) welding procedure specifications shall be compiled by the manufacturer in accordance with EN 288-2 for each joint or family of joints;
- b) the welding procedure specifications selected by the manufacturer shall be approved for the field of application;
- c) the welders and welding operators shall be qualified for the work allocated to them and their approvals shall be valid.

8.1.5 Where the use of oxy-acetylene welding is proposed, the manufacturer shall demonstrate that the location of such welds in the boiler will not result in subsequent problems in the operation. The method of procedure approval shall be in accordance with the requirements of EN 288-3 or EN 288-8. Welder approval shall be in accordance with the requirements of EN 287-1.

8.1.6 Butt welds shall not be permitted on the bends of tubes, except in the special case of coil boilers – see annex D.

8.1.7 The toes of welds of attachments to main pressure parts should, wherever practicable, not be located closer than 40 mm to main joint welds. If this latter condition is not practicable, the attachment weld shall cross the main joint weld completely. In such cases, the surface of the main joint weld and the attachment welds shall be ground locally after the welding-on of the attachment has been completed.

The portion of attachment welds which crosses main joint welds shall be treated as "load-carrying" with respect to the non-destructive examination to be applied. Such NDE shall be carried out in accordance with the requirements of 6.7 of EN 12952-6.

Openings for branches should, if practicable, be positioned away from main joint welds of drums and headers. The spacing shall be considered adequate if the distance between the edge of the main joint weld and the edge of the branch or set-on reinforcement fulfils the requirements given in table 8.1-1.

Table 8.1-1 — Spacing between branches and main joint welds

Drum or head thickness e mm	Spacing $s$ mm
$e \leq 25$	$s > 2 \times e$
$e > 25$	$s > 50$

If, for reasons of design, these spacings cannot be achieved the welds shall be capable of being non-destructively examined within the area of influence of the opening and the welds shall be ground to a smooth profile to remove all notches in this area.

Where local grinding of the welds is required, as indicated above, the ground surface shall be 100 % non-destructively examined in accordance with the requirements of clause 9 of EN 12952-6.

The machining of holes in longitudinal butt welds shall not be permitted. Holes machined through the centre of circumferential butt welds shall be permitted, provided that the welds have been subjected to non-destructive examination in accordance with the requirements of clause 9 of EN 12952-6 over the length of the seam to be machined.

8.1.8 When boiler drum strakes cannot be manufactured from single plates they shall be completed with the minimum number of longitudinal joint welds. Non-destructive testing of main joints, see clause 9 of EN 12952-6, shall be performed after any forming/re-rolling operations have been completed.

8.1.9 Where any parts of the boiler drum are to be made in two or more strakes, the welding of the longitudinal joints shall be completed before the welding of the connecting circumferential joints is commenced. The longitudinal joints of adjacent strakes shall be staggered unless the construction of the drum makes this impracticable e.g. thick and thin profile.

8.1.10 The welding on site of widely differing materials, e.g. austenitic to ferritic materials, should be avoided whenever possible.

8.1.11 Where necessary, staging and protection from the weather shall be provided to enable the welding operations to be performed under satisfactory conditions.

8.1.12 During production, a copy of the welding procedure specification shall be available to the welder.

## 8.2 Welding consumables

Electrodes, filler wires, filler rods, fluxes, fusible inserts, shielding and purge gases shall either:

- a) comply with the relevant European Standards; or
- b) where relevant European Standards do not exist, comply with the relevant national standards.

The manufacturer shall ensure that the correct consumables, as stated in the welding procedure specification, shall be used during manufacturing operations.

All consumables including gases shall be stored and handled with care, and used in accordance with the conditions specified by the consumable manufacturer.

NOTE This is particularly important in the case of the requirements for baking and drying when hydrogen controlled consumables are to be used.

Electrodes, filler wires, filler rods and fusible inserts that show signs of damage or deterioration, such as cracked or flaked coatings or rusting or dirty electrode wire, shall not be used. Fluxes shall be clean and dry.

## 8.3 Welding approvals

### 8.3.1 Approval of fusion welding procedures

Approval of fusion welding procedure specifications shall be carried out in accordance with EN 288-3 or EN 288-8 (see clause 6 of EN 12952-6).

The welding procedures for the butt welding of metallurgically bonded composite materials tubing shall be in accordance with the requirements of EN 288-8. In addition, any special requirements recommended by the tube manufacturer shall be taken into consideration. The procedures shall be qualified using composite materials tubing complying with the same specification as the tubing to be used on the boiler.

### 8.3.2 Approval and training of welders

Welders and welding operators approval shall be carried out in accordance with EN 287-1, 4.2.1 and 4.2.2 of EN 1418 respectively (see clause 7 of EN 12952-6). The training, supervision and control of welders and welding operators shall be the responsibility of the manufacturer.

Welders involved in the butt welding of metallurgically bonded composite materials tubing shall be approved in accordance with the requirements of EN 287-1, 4.2.1 and 4.2.2 of EN 1418 respectively. In addition, any special requirements recommended by the tube manufacturer shall be taken into consideration. The approval shall have been carried out using composite materials tubing complying with the same specification as the tubing to be used on the boiler.

## 8.4 General production requirements for welding

### 8.4.1 Surface condition before welding

The fusion faces and the adjacent material on the inner and outer surfaces shall be dry and thoroughly cleaned of grease, oil, lubricants, marking paints, oxide scale or other foreign substances to a clean metal surface for a distance from the welding edges sufficient to prevent contamination of the weld. Appropriate compatible materials shall be used for cleaning purposes.

#### 8.4.2 Assembly of components for welding

To maintain, during welding, the specified alignment (see 7.4.1) and, where required, the details for any root gap given in the drawings and welding procedure specifications (see 8.1.3), the parts to be welded shall be securely held in position by mechanical means, welded bridge pieces or tack welding.

NOTE The dimensions of the root gap are the dimensions after any tack welding.

It is recognized that there may be difficulty in complying strictly with the requirements for the root gap. Minor modifications imposed by practical considerations shall be permitted, providing the manufacturer can ensure that the safety of the boiler is not impaired.

Correction of irregularities in fit-up shall not be carried out by hammering.

#### 8.4.3 Temporary attachments

Temporary attachments welded to the pressure parts shall be kept to a practical minimum.

Temporary attachments (except hydraulic testing blanks) shall be removed prior to the first pressurization unless they have been designed to the same requirements as permanent attachments. The removal technique shall be such so as to avoid, as far as practicable, impairing the integrity of the pressure part and shall be by chipping, grinding or thermal cutting followed by chipping or grinding. Any rectification necessary by welding of damaged regions after removal of attachments shall be undertaken by approved welders working to an approved welding procedure specification.

All temporary attachments shall be removed. The associated weld area shall be ground flush and examined by a surface flaw detection method appropriate to the material before any stress relief heat treatment is applied.

The preheating requirements of 10.3 shall be applied and maintained during tack welding and the welding of bridge pieces or other attachments.

Filler materials used for tack welding shall be of a designation appropriate to the particular weld and shall be deposited in accordance with an approved welding procedure specification.

Particular attention shall be paid to the quality of tack welds which shall be deposited by approved welders. Where necessary, the ends of these tack welds shall be dressed by grinding or chipping to facilitate proper fusion if they are to be incorporated into the root run. Any cracked tack welds shall be completely removed.

#### 8.4.4 Stray arcing

While arc strikes are to be avoided, any accidental arc strikes shall be ground smooth and the parent material examined by a surface flaw detection method appropriate to the materials.

#### 8.4.5 Traceability of welders

A list of welders and welding operators, together with records of their approval tests, shall be retained by the manufacturer who may be required to provide evidence of approval of any welder engaged in the fabrication of water-tube boilers.

### 8.5 Repairs to welds

#### 8.5.1 General

If it is found necessary to repair a weld, an approved welding procedure and an approved welder shall be used. The nature and extent of such repairs shall be reported as part of the manufacturer's data dossier. When films or other records of non-destructive examinations are being examined, the manufacturer shall make available all previous relevant records of the repaired areas. Details of weld repairs shall be made available to non-destructive examination personnel responsible for re-examination.

Defects shall be cut out by an appropriate method. Where welds are partially removed, the portion cut out shall be sufficiently deep and long to remove the whole defect. At the ends of the cavity, there shall be a gradual taper from the base of the cut to the surface of the weld metal. The width and profile of the cut shall be such as to give adequate access for re-welding.

#### 8.5.2 Repair of longitudinal and circumferential butt welds of drums and headers requiring test plates

If the whole of the weld is removed and the butt weld re-welded, a new production test plate shall be provided if required by 8.2 of EN 12952-6.

When butt welds have been repaired, the component and the test plates (if any) shall be heat treated in accordance with the relevant clauses of this European Standard, and the test plates (if any) shall be tested in accordance with clause 8 of EN 12952-6.

#### 8.5.3 Non-destructive examination

All repaired areas and re-welded joints shall be subjected to non-destructive examination in accordance with clause 9 of EN 12952-6 and shall be subjected to the same testing and inspection requirements as the original joints.

#### 8.5.4 Records of weld repairs

The manufacturer shall maintain records showing the position, length, width and depth of all repairs carried out on:

- a) drum longitudinal and circumferential butt welds and nozzle welds;
- b) header longitudinal and circumferential butt welds;
- c) butt welds in integral tubes over 25 mm thickness or over 170 mm outside diameter.

Repairs made to other welds shall be recorded in the relevant NDE report.

#### 8.6 Pre-heating

Pre-heating should be in accordance with 10.3.

#### 8.7 Post-weld heat treatment

Post-weld heat treatment shall be in accordance with 10.4.

Welded components which are subjected to normal methods of manufacture and comply with the requirements of 10.4.1.4, 10.4.1.5 and 10.5 would not be expected to suffer unacceptable degradation of material property values during heat treatment. Attention is, however, drawn to the fact that welds in components which are subjected to normalizing heat treatment may suffer property degradation.

When testing material after heat treatment for components designed to operate in the proof stress range at elevated temperatures, base material values up to 5 % lower than the specified minimum yield stress and the specified minimum tensile strength shall be permitted in individual cases. Values lower than the specified minimum yield stress and the specified minimum tensile strength by between 5 % and 10 % shall be permitted if it can be demonstrated that:

- a) the heat treatment has been performed correctly;
- b) the requirements regarding base material elongation at fracture have been met;
- c) the requirements regarding base material impact energy have been met;
- d) the component wall thickness is adequate for the design with the proof stress value obtained.

For components designed to operate in the creep range values lower than the specified minimum yield stress and the minimum specified tensile strength shall be permitted up to a maximum of 10 %.

## 8.8 Welding subsequent to final post-weld heat treatment

Special cases may arise when it is necessary to weld to a pressure part after the final post-weld heat treatment has been completed, e.g. the welding of isolated minor attachments and effecting isolated minor repairs<sup>1)</sup>. This practice shall be permitted on steel groups 1.1, 1.2, 5.1 and 5.2 in accordance with CR ISO 15608 provided that the welding complies with an approved welding procedure specification in accordance with the requirements of EN 288-3, taking into account the following requirements.

- a) Minimum pre-heating shall be in accordance with 10.3. For steels 5.1 and 5.2 the preheating temperature should be  $\geq 200$  °C.
- b) Either hydrogen controlled welding electrodes, dried to at least the requirements of prEN 1011-2, scale "D", shall be used or, alternatively, a process giving similar potential hydrogen levels shall be used, e.g. TIG welding.
- c) Where practicable, at least two runs of weld metal shall be deposited with the minimum number of stop and starts. For Cr-Mo steel at least two runs shall be applied.
- d) The throat thickness of attachment welds shall not exceed 13 mm.
- e) For Cr-Mo steels the nozzle dimensions should not exceed 57 mm outside diameter by 10 mm thick.
- f) The weld metal shall blend smoothly with the component material and shall be dressed if required.
- g) After completion of all welding and, if necessary, dressing as required, the welds shall be examined by magnetic particle inspection.
- h) The special requirements for the seal welding of expanded tubes are given in 9.4.

## 8.9 Welded joints, connections and production test plates

### 8.9.1 Longitudinal and circumferential butt welds and test plates in drums and headers

8.9.1.1 When multi-run welding is employed, each deposited run shall be clean and free from slag before any subsequent runs are deposited, except as shall be permitted by the welding procedure specification.

8.9.1.2 When backing materials are employed in welding longitudinal and circumferential butt welds of drums, they shall be removed after welding.

8.9.1.3 The location of any flushed longitudinal and circumferential butt welds in boiler drums shall be permanently marked (see 6.4.2).

8.9.1.4 Permanent backing rings shall not be used for butt welds in headers.

8.9.1.5 Fusible inserts shall not be regarded as backing rings. Fusible inserts shall be used only if the material from which they are made is compatible with the parent metal and if they are completely fused into the joint.

8.9.1.6 Where a butt welded joint is required between plates of different thicknesses, the thicker plate shall be reduced in thickness by one of the methods shown in figures 8.9-1 and 8.9-2. The thicker plate shall be trimmed to a smooth taper as indicated in figures 8.9-1 and 8.9-2 including, where necessary, the width of the weld. If necessary the required taper shall be obtained by adding additional weld metal beyond the width of what would otherwise be the edge of the weld. Where US testing is required, adequate measures shall be taken to ensure the weld can be suitably scanned.

---

<sup>1)</sup> Whilst it is difficult to define minor repairs, an excavation of maximum length of 100 mm and a depth of  $e/10$  (where  $e$  is the component nominal thickness) or 6 mm maximum depth may be considered minor, but values greater than this may be exceeded.

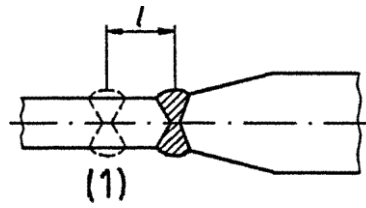

a) Shell to shell joint

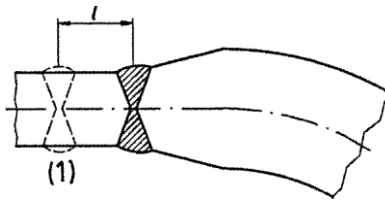

b) Shell to end joint-end thicker than the shell

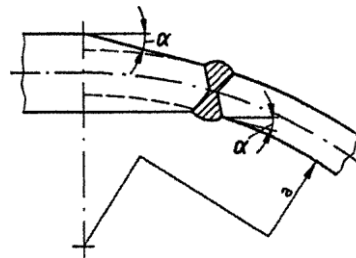

c) Shell to end joint-end thinner than the shell

key

$\alpha$   $\leq 15^\circ$  see also figure 10.2-3 of EN 12952-3.

$a$  is  $R_i$  or  $r_i$

$l$  is the parallel length

(1) is the position of weld

NOTE 1 In cases a) and b), the position of the weld (1) and the parallel length  $l$  is in accordance with the manufacturers normal practice.

NOTE 2 Tapers may include the weld if desired, but no taper is required if the difference in thickness is less than 3 mm.

NOTE 3 Internal and external tapers need not be symmetrically disposed.

NOTE 4 For typical details of welded connections see annex B.

Figure 8.9-1 — Butt welds in plates of unequal thickness with middle lines coincident

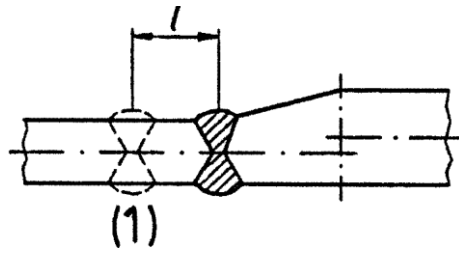

a) Shell to shell joint

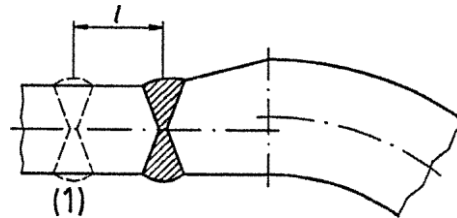

b) Shell to end joint

NOTE 1 In cases a) and b), the position of the weld (1) and the parallel length  $l$  is in accordance with the manufacturer's normal practice.

NOTE 2 Tapers may include the weld if desired, but no taper is required if the difference in thickness is less than 3 mm.

NOTE 3 Internal and external tapers need not be symmetrically disposed.

NOTE 4 Tapers may be inside or outside the vessel.

NOTE 5 For typical details of welded connections see annex B.

Figure 8.9-2 — Butt welds in plates of unequal thickness with middle lines offset

EN 12952-5:2001 (E)

8.9.1.7 Production control test plates for boiler drums shall be in accordance with clause 8 of EN 129526.

#### 8.9.2 Welded header end closures

8.9.2.1 Torispherical, semi-ellipsoidal or hemispherical ends shall be secured to the header shell by welding in accordance with 8.9.1.

8.9.2.2 Flat ends shall be secured to the header shell by welding as specified in 10.3 of EN 12952-3 accordance with 8.9.1 or 8.9.3 as appropriate.

The extent of non-destructive examination of flat end plate welds as specified in 10.3 of EN 12952-3 shall be accordance with clause 9 of EN 12952-6.

#### 8.9.3 Welded branches, nozzles, stubs and other attachments on drums and headers

Not less than two runs of metal shall be deposited at each weld. Each run of weld metal shall be clean and free from slag before the next run is deposited.

Permanent backing rings shall not be used.

Fusible inserts shall not be regarded as backing rings. Fusible inserts shall be used only if the material from which they are made is compatible with the parent metal and if they are completely fused into the joint.

Where the use of partial penetration welds is specified, the depth of penetration shall be given on the drawing.

The surface of the completed weld shall be free from irregularities between weld runs and the final finish of all welds shall be such that the change of section between the parts is gradual and free from sharp notches and significant undercutting, see 9.3.5 of EN 12952-6.

Attachment welds of branches, nozzles and stubs on drums and headers shall not involve any combination of austenitic and ferritic steels although minor instruments connections made from austenitic steels are permissible. Composite tubes shall have the composite layer removed at the weld end preparation before they are welded towards any drum or header. It is not allowed to melt any austenitic steel into the weld pool, when the carbon steel component is welded.

NOTE Guidance concerning typical welded connections is given in annex B.

#### 8.9.4 Pads, reinforcing plates and manhole frames

All pads, reinforcing plates, manhole frames, and other attachments which contribute to the strength of the pressure part, shall fit closely and the gap at all exposed edges to be welded shall not exceed 2 mm or 5 % of the thickness of the attachment at the point of attachment, whichever is the greater.

Where reinforcing plates or manhole frames are fitted, they shall be provided with tell-tale holes through the outer plate.

Manhole frames of the pressed type shall bed closely to the surfaces to which they are to be connected and shall be fillet-welded to the inner surface of the drums.

Manhole frames which are set through the drum plates shall be either formed in one piece without welding, or formed from a suitable rolled section fabricated by fusion welding providing they are stress relieved after welding and before attachment to the drum, unless the whole drum is to be stress relieved on completion. The welds shall also be subjected to non-destructive examination in accordance with clause 9 of EN 12952-6. Butt welded manhole frames positioned on the shell shall be such so that the welds are in a plane at right angles to the longitudinal axis to the drum.

Except where specific dimensions are shown on the drawing, the maximum gap between the outside of any branch or shell and the inside edge of the hole in the shell, flange, reinforcing ring or backing ring shall not exceed 1,5 mm for openings up to 300 mm, and 3 mm for openings over 300 mm.

NOTE To achieve this gap, the outside diameter of the shell or nozzle may be machined over a sufficient length to accommodate the attachment to which it is to be welded.

#### 8.10 Attachment of non-pressure parts to drums and headers by welding

The attachment of non-pressure parts (e.g. brackets, lugs stiffeners, supports, flats etc, including drum internal fittings) to drums and headers by welding shall be permitted.

The welds of attachments designated as load carrying, see 5.8 of EN 12952-3, shall be continuous. These welds shall be around the perimeter of the attachment, and may be double sided partial penetration welds, a single-sided full penetration weld or double-sided full penetration welds. The type of joint selected shall be subjected to the relevant NDE as specified in clause 6 of EN 12952-6.

It is permissible for the welds of non-load carrying attachments to be made by intermittent fillet welds.

When multi-run welding is employed, each run of weld metal shall be cleaned to ensure a sound weld before the next run is deposited.

Preheating and post-weld heat treatment shall be applied in accordance with 10.3 and 10.4 respectively.

#### 8.11 Welding of tubes

##### 8.11.1 General

In addition to conforming to the appropriate parts of 8.1 to 8.8, the following requirements shall be applied to the welding of tubes.

##### 8.11.2 Continuity of welding

Irrespective of the type of steel, root runs shall be made without interruption other than for the changing of electrodes or filler metal, or to allow the welder to re-position himself. Welds requiring preheat, which are made at site, shall not be allowed to cool until the thickness of the weld metal deposited exceeds one third of the final thickness.

EN 12952-5:2001 (E)

When welding other than carbon or carbon manganese steels, if an unavoidable interruption becomes necessary, preheating temperatures shall be maintained during the interruption. If this is not possible, the joint shall be wrapped in a dry insulating blanket to ensure slow cooling. Preheat shall be re-applied before further welding is commenced.

NOTE 1 It is strongly recommended that any interruptions to the welding should be avoided whenever possible.

NOTE 2 Completed root runs made in the workshop, may be allowed to cool provided that precautions are taken to ensure slow cooling e.g by wrapping in a dry insulating blanket.

### 8.11.3 Completion of welding

In order to minimize the risk of hydrogen cracking, on completion of the welding, especially with higher alloy Cr-Mo steels and in thick materials, the joint shall be wrapped in dry thermal insulating blankets to ensure slow cooling, unless any specified post-weld heat treatment is to be applied immediately, or if preheating is to be maintained.

### 8.11.4 Proximity of butt welds

For tube diameters up to and including 250 mm, butt welds shall not be positioned closer than twice the outside diameter of the tube. When the outside diameter of the tube is greater than 250 mm, butt welds shall not be positioned closer than 500 mm.

### 8.11.5 Alignment of tube bores

The welding of tube joints conforming to this European Standard shall include matching, if necessary, by the manufacturer of the tube ends at each joint.

Matching of the bores shall be effected by selection, drifting (hot or cold), machining, swaging or by use of a suitable expander. Any machine counter boring required shall not reduce the thickness of the tube wall to below the design thickness. All hot drifted ends shall be heat treated in accordance with requirements of the relevant material standard, or data sheet, as appropriate.

The bores of the ends of adjacent tubes should preferably match exactly. Permissible limits for bore difference and bore misalignment are given in table 8.11-1.

Table 8.11-1 — Alignment tolerances of tube bores

Diameter of tube bore mm	Max. difference in bore mm	Max. out of alignment of adjacent tube mm
Up to 80	1,0	1,0
80 to 300	1,5	1,5
Over 300	2,0	2,0

### 8.11.6 Angular alignment of butt welded tubes

Any centre line angular misalignment should not normally exceed 3°, i.e. 5 mm in 100 mm, (see figure 8.11-1), but in any case should be consistent with any specific design requirements.

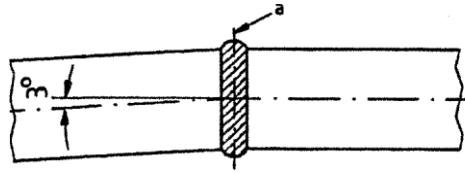

key  
a Centre line of weld

Figure 8.11-1 — Angular alignment of butt welded tubes

#### 8.11.7 Fabricated bends

Segmental and cut-and-shut type bends shall not be permitted.

#### 8.11.8 Backing rings

Permanent backing rings shall not be used in the tubes of the evaporative circuit.

Temporary steel or non-metallic backing rings, which are compatible with, or inert to, the parent tube material, may be used. These shall be removed completely after the completion of welding.

#### 8.11.9 Purging of welds

When back purging is specified in the welding procedure specification, the air shall be removed from the vicinity of the weld by the admission of a sufficient volume of purging gas such that oxidation of the root zone is prevented. Purging shall be carried out by passing the purging gas through the full length of the tube, or by local purging, using temporary dams. Such dams shall be removed by the manufacturer after the completion of welding.

#### 8.11.10 Welding of branches, nozzles and stubs to tubes

Not less than two runs of metal shall be deposited at each weld. Each run of weld metal shall be clean and free from slag before the next run is deposited.

Permanent backing rings shall not be used.

Fusible inserts shall be permitted and shall be used only if the material from which they are made is compatible with the parent metal and if they are completely fused into the joint.

The surface of the completed weld shall be free from irregularities between weld runs and the final finish of all welds shall be such that the change of section between the parts is gradual and free from sharp notches and undercutting in excess of that permitted by 9.3.5 of EN 12952-6.

Preheating, where required, shall be carried out in accordance with 10.3.

Welds attaching branches, nozzles and stubs to tubes shall not involve any combination of austenitic and ferritic steels.

NOTE Guidance concerning typical methods of attachment of nozzles, branches and connections are given in annex B.

EN 12952-5:2001 (E)

#### 8.11.11 Attachment by welding of non-pressure parts to tubes

The welds of attachments designated as load carrying (see 5.8 of EN 12952-3) shall be continuous. This weld shall be a fillet weld around the perimeter of the attachment, a partial penetration weld, a single-sided full penetration weld or a double-sided full penetration weld. The type of joint selected shall be subjected to NDE as specified in clause 9 of EN 12952-6.

It is permissible for the welds of non-load-carrying attachments to be made by intermittent fillet welds.

When multi-run welding is employed, each run of weld metal shall be cleaned to ensure a sound weld before the next run is deposited. Preheating and post-weld heat treatment shall be applied when required by 10.3 and 10.4 respectively.

#### 8.12 Flash butt welding of tubes

The flash butt welding of tubes shall be in accordance with the requirements of the appropriate European Standard.

In the absence of such a European Standard the use of nationally or internationally recognized standards for the flash butt welding of tubes shall be permitted.

#### 8.13 Welded tube water walls

The methods of construction of water wall panels and the required controls are given in annex C.

#### 8.14 Arc stud welding

Welding procedure qualifications, welder qualifications and pre-production tests for arc stud welding shall be generally in accordance with the requirements of EN ISO 14555. In each case qualifications shall include macro tests. Studs made of high alloy material may have hardness values in the weld which exceed the limitations given in table 2 of EN 288-3.

Process control shall be monitored, as a minimum, by the "Simplified Production Test" described in EN ISO 14555.

For stud welds on tubes with outside diameters less than 80 mm, an incomplete weld rag shall be acceptable, provided there is no gap between the tube surface and the stud.

### 9 Mechanical connections

#### 9.1 General

Mechanical connections are those which do not involve strength welding between the connected parts (see also 8.4 or 8.5 of EN 12952-3).

#### 9.2 Access openings

##### 9.2.1 Type

All drums, headers and other large parts of boilers shall be provided with manholes, headholes, handholes, or other inspection openings as appropriate, to permit internal examination and effective cleaning. It is permissible to provide openings to facilitate manufacture and maintenance.

NOTE Access may be gained for these purposes by cutting and re-welding tubes or blind nozzles. Inspection openings may, where necessary, be closed by nozzles with welded caps.

For calculation pressures exceeding  $1,8 \text{ N/mm}^2$ , openings in pressure parts with mechanical closures shall be of the internal door type. For calculation pressures of  $1,8 \text{ N/mm}^2$  and below, circular external or elliptical doors of the blanked flange type is permitted.

### 9.2.2 Size

The minimum sizes of access openings, together with the associated restrictions on nozzle or ring height, are given in 4.6.4 of EN 12952-7.

### 9.2.3 Internal doors

Internal doors shall be made from steel in accordance with EN 12952-2 and constructed in accordance with the following:

- a) Doors shall be formed to fit closely to the internal joint surface and shall be fitted with studs, nuts and crossbars.
- b) Doors for circular openings larger than 250 mm diameter or elliptical or rectangular openings larger than 250 mm × 175 mm shall be provided with two studs. Doors for openings of these sizes and below, may be provided with one stud. Doors for openings not larger than 123 mm diameter or 123 mm × 90 mm may have the stud forged integrally with the door.
- c) Door studs shall be made from steel of a quality that may be welded and have a minimum tensile strength of not less than 355 N/mm<sup>2</sup>. Studs used for manhole doors shall not be less than 30 mm diameter. The studs shall be fixed to the door by one of the following methods:
  - 1) screwed through the door and fillet welded on the inside;
  - 2) let through the door and fillet welded each side of the door with a weld of leg length not less than 10 mm;
  - 3) attached to the door by an intermediate plate or lugs with the strength of the attachment not being less than that of the stud and designed to prevent the studs from turning;
  - 4) provided with an integral collar, screwed into blind holes in the door and shall be prevented from turning.
- d) When the door is in a central position the spigots should have an all-round clearance of approximately 1,5 mm, but at no point shall the clearance exceed 3 mm. The spigot depth shall be sufficient to trap the gasket.

NOTE For the selection of gasket materials see 4.6.6 in EN 12952-7.

- e) Nuts shall comply with the appropriate European Standard and be faced on the seating surface.
- f) Crossbars shall be made from steel in accordance with EN 12952-2 having a minimum specified tensile strength of not less than 355 N/mm<sup>2</sup>. The seating surface shall be faced.

NOTE Eyebolts with suitable lugs on the door plate, or headed bolts engaging with slotted sections on the door plate, may be used instead of studs.

### 9.2.4 External doors

Circular external doors of the blank flange type shall be designed in accordance with the requirements of 10.4 of EN 12952-3. The design shall incorporate a spigot and recess of sufficient dimensions to completely trap the gasket.

NOTE For the selection of gasket materials see 4.6.6 of EN 12952-7.

## 9.3 Branches and nozzles mechanically connected to the main pressure parts

### 9.3.1 Scope and restrictions

The following methods of mechanically connecting branches or nozzles to the main pressure part shall be permitted:

- a) Expanding and belling; restricted to branch and nozzle outside diameters not exceeding 48,3 mm (for tube connections see 9.4);

EN 12952-5:2001 (E)

- b) Expanding and seal welding; restricted to steels having a carbon content not exceeding 0,25 % (product analysis) and branch and nozzle outside diameters not exceeding 48,3 mm (for tube connections see 9.4);
- c) Screwing or screwing and seal welding directly into the pressure part; subject to the requirements of 8.5.1 of EN 12952-3;
- d) Screwing or screwing and seal welding into a socket; subject to the requirements of 8.5.2 and 8.5.3 of EN 12952-3, or;
- e) By studs; subject to the requirements of 8.4 of EN 12952-3.

### 9.3.2 Screwed connections

The requirements of 8.5 of EN 12952-3 shall apply.

### 9.3.3 Studded connections

Studs shall be designed in accordance with the requirements of 8.4.5 of EN 12952-3. The design shall ensure that high fatigue strength is achieved and shall have a full thread engagement in the main pressure part equal to at least one diameter of the stud. Stud shall not completely pierce the pressure part and, after allowing suitable clearance at the blind end of the stud, the unpierced material of the pressure part shall amount to not less than one quarter of the stud nominal diameter.

After the machining of the jointing faces, the final thickness of the pressure part shall not be less than the minimum thickness required by clauses 7, 8, 9 or 10 of EN 12952-3, as appropriate.

## 9.4 Tube connections

### 9.4.1 Expanded connections

- a) It shall be permissible to attach tubes to drums and headers other than by welding. Attachment shall be made by expanding, expanding and belling, or provided the requirements of b) are satisfied, by expanding and seal welding. The method of expanding is normally by use of mandrels.

It is also permissible to use other methods of expanding but in such cases it shall be demonstrated that the method provides adequate leak tightness and will prevent tube withdrawal in service. The provision of documented evidence of satisfactory performance in service shall be considered as satisfying these requirements.

The nominal outside diameter of the tube connected by expanding shall not exceed 115 mm.

Attachment by expanding may be achieved with or without the use of expansion grooves (see figure 9.4).

- b) When expanded joints are to be seal welded the following restrictions shall be observed:
  - The drum or header material shall be limited to steel groups 1.1, 1.2 or 5.1 (see CR TR 15608).
  - The welding pre-heat temperature shall be in accordance with 10.3.
  - The fillet weld shall be made with a minimum of two runs with the stops/starts staggered between runs.
  - The fillet weld size shall not exceed 8 mm.
  - Either hydrogen controlled welding electrodes, dried to at least the requirements of scale D of prEN 1011-2 shall be used or, alternatively, a process giving similar potential hydrogen levels shall be used, e.g. TIG welding.
  - The welding procedure shall be supported by a welding procedure qualification in accordance with EN 288-3.
  - When the room temperature yield strength of the drum or header material is in excess of 300 N/mm<sup>2</sup> further expansion of the joint shall be applied after seal welding to reduce the local shrinkage stresses in the joint.
  - Surface crack detection of the seal weld shall be carried out in accordance with the requirements of clause 9 of EN 12952-6.
- c) Tube holes for expanded tubes shall provide a region of parallel seating of not less than 13 mm and shall be formed in such a way that the tubes can be effectively tightened in them. The surface finish shall be no coarser than 6,3 µm (R<sub>a</sub>). The surface shall exhibit no spiral or longitudinal score marks which could form a leak path.

Where the tubes are not radial to the drum or header shell, there shall be a region of parallel seating in the tube hole at right angles to the axis of the tube. The region shall be at least 13 mm long measured in a plane containing the axis of the tube at the hole.

- d) Where tubes are fitted by propulsive expanding, they shall be belled out from the edge of the tube hole at an angle to the tube axis to resist withdrawal. In no such case shall the projection of the tube through the parallel tube seat be less than 6 mm and the beelling shall be not less than given in table 9.4.

Table 9.4 — Belling dimensions for tubes propulsively expanded

Outside diameter of tube mm	Minimum increase in diameter of belling over diameter A (see figure 9.4) of tube holes mm
$d_o \leq 51$	3
$51 < d_o \leq 82,5$	4
$82,5 < d_o \leq 115$	5

Dimensions in millimetres

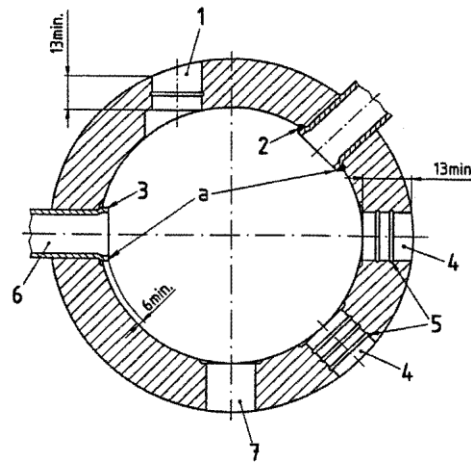

key

- 1 Non-radial hole
- 2 Seal weld
- 3 Bell
- 4 Radial hole with grooves
- 5 Expansion grooves
- 6 Radial hole
- 7 Radial hole without grooves

a belling over diameter

Figure 9.4 — Various typical features relating to tube expansions

#### 9.4.2 Tube to tube mechanical connections

It shall be permissible to join unheated tubes together by mechanical connections or mechanical connections plus seal welding, see 11.7 of EN 12952-3 for requirements and limitations.

It shall be not permissible to use mechanical connections to join those portions of tubes together that are to be exposed to furnace radiation or the passage of hot flue gasses.

#### 9.5 The connection of non-pressure parts to pressure parts

It shall be permissible to connect non-pressure parts to pressure parts by mechanical means.

NOTE Typical instances are for the support and location of the pressure parts, drum internals, insulation, casing and cladding.

### 10 Thermal treatment

#### 10.1 General

Heating cycles and heat treatment(s) associated with forming operations, other than for the bending of tubes, shall be in accordance with 10.2 The heat treatment requirements associated with the bending of tubes shall be in accordance with 7.3.8 and 7.3.9. Pre-heating shall be in accordance with 10.3. Post weld heat treatment shall be in accordance with 10.4. The heat treatment of production test plates shall be in accordance with 10.5.

#### 10.2 Heating cycles and heat treatment(s) associated with plate forming operations

##### 10.2.1 Heating cycles associated with hot forming

The heating cycles applied during hot forming shall be based on the values given in the base material specification or data sheet.

NOTE 1 Other heating cycles may be applied, if in accordance with a qualified procedure approved, and the product is to be tested after forming to demonstrate the adequacy of the material property values in the finished component.

All forming shall be carried out to documented procedures which shall specify, as a minimum, the plate heating rate, the holding temperature, the temperature range and the details of any subsequent heat treatment to be given to the formed part.

NOTE 2 Ferritic steels. Hot forming is a process which is performed in the austenite region. In view of the danger of excessive grain growth, the component should be austenitized at a specified maximum temperature above  $A_{c3}$ , but not higher than  $1\ 020\ ^\circ\text{C}$ , and after reaching the specified temperature, the component should remain at this temperature for as short a time as possible to avoid grain growth. The heating rate should be as fast as possible e.g.  $150\ ^\circ\text{C}/\text{h}$ , through the transition range and, after forming, the component should be allowed to cool freely in still air.

For components made from normalized steels (steel groups 1.1, 1.2 and 2.1), which are formed in a single operation, the maximum temperature of the component shall not be above  $980\ ^\circ\text{C}$ .

For components formed by several operations, the maximum specified temperature of the component shall not exceed  $1\ 020\ ^\circ\text{C}$ . Before the last operation, the component shall be cooled to below  $500\ ^\circ\text{C}$ , with final heating restricted to a maximum specified of  $980\ ^\circ\text{C}$  for steels with specified minimum yield strengths  $R_{p0.2}$  of  $\leq 355\ \text{N}/\text{mm}^2$  and  $940\ ^\circ\text{C}$  for steels with specified minimum yield strengths  $R_{p0.2}$  of  $> 355\ \text{N}/\text{mm}^2$ . If no subsequent heat treatment is to be applied, the last operation of the forming process shall be completed above  $750\ ^\circ\text{C}$ , or above  $700\ ^\circ\text{C}$  where the degree of deformation does not exceed 5 %.

After hot forming under the conditions detailed above, the component shall be allowed to cool in still air.

For components made from quenched and tempered steels, it shall be essential, that a totally new quenching and tempering operation is performed on the whole component after hot forming. For the hot forming itself, the procedures described in 7.3.9.1a) shall apply.

NOTE 3 Austenitic steels The forming requirements applicable to austenitic steel plate are the subject of development. In the meantime the methods used in accordance with the manufacturer's own proven procedures ensure that, by their use, the safety of the boiler is not impaired.

#### 10.2.2 Heat treatment associated with forming

The heat treatment required by this European Standard, after hot or cold forming, depends on the requirements of the base material specification or data sheet, and normally be one of the following processes:

- Normalizing;
- Normalizing plus tempering;

NOTE Tempering may be part of the stress relieving process of welds, if applicable.

- Quenching plus tempering;
- Solution annealing.

Other heat treatment(s) may be applied, if they are in accordance with a qualified procedure, and the product shall be tested after forming to demonstrate the adequacy of the material property values in the finished component.

#### 10.2.3 Shells and strakes

Where a plate is bent to a mean radius less than ten times the plate thickness, it shall be heat treated after bending to the requirements of 10.2.2. However, in the case of materials for which normalizing or normalizing and tempering are the final heat treatments specified in the material specification, or data sheet, the following shall apply:

- a) When the final heat treatment specified is normalizing, providing the component has been heated uniformly to the normalizing temperature during forming, no further heat treatment is required;
- b) When the final heat treatment specified is normalizing and tempering, providing the component has been heat treated uniformly to the normalizing temperature during forming, only additional tempering is required.

#### 10.2.4 Ends

All ends made from plate shall be heat treated after forming to the requirements of 10.2.2. However, in the case of materials for which normalizing or normalizing and tempering are the final heat treatments specified in the material specification, or data sheet, the following shall apply:

- a) When the final heat treatment specified is normalizing, providing the component has been heated uniformly to the normalizing temperature during forming, no further heat treatment is required;
- b) When the final heat treatment specified is normalizing and tempering, providing the component has been heat treated uniformly to the normalizing temperature during forming, only additional tempering is required.

#### 10.2.5 Production test requirements for formed components

Production test coupons shall be provided for hot formed shells, strakes and ends. The number of test coupons required shall be as follows:

- a) Shells and strakes – One test coupon per drum. This may, at the manufacturer's risk, be produced as an extension of the weld production test plate, provided that the test plate has been made from the same material as that supplied for the shells or strakes and which has been heat treated with one of the shells or strakes.

EN 12952-5:2001 (E)

b) Ends – One test coupon per heat treatment batch.

The coupons shall be tested to replicate the mechanical tests carried out on the base material by the material supplier.

In the event of a failure of any of the production tests, further testing shall be permitted. This shall be in accordance with the re-testing procedures given in the material specification or data sheet.

### 10.3 Pre-heating for welding and thermal cutting

#### 10.3.1 General

To avoid hard zone cracking in the heat-affected zones of welds and thermally-cut surfaces, consideration shall be given, where appropriate, to the application of pre-heating prior to the commencement of welding, including tack welding, and thermal cutting.

No welding or thermal cutting operations shall be carried out on boiler components when the temperature of the component in the welding or cutting zone is below 5 °C.

NOTE When necessary, staging and protection from the weather should be provided to ensure the welding or thermal cutting operations can be performed under satisfactory working conditions.

#### 10.3.2 Pre-heating for welding

10.3.2.1 The manufacturer shall include in the welding procedure specification the pre-heating temperatures and, where relevant, the inter-pass temperatures required for the welding. The pre-heat temperature shall be determined by taking into consideration the welding process, the composition and thickness of the metal being welded, the type of joint, the consumable being used and the heat input involved. General recommendations for pre-heating are contained in EN 1011-1.

10.3.2.2 Where the welding process employed for the root runs differs from that used for subsequent runs, the pre-heating, if any, applicable to each process, shall be determined separately. Any change in pre-heating temperature required, shall be made after the completion of welding by the first process, but before the next process is commenced.

10.3.2.3 Where the risk of hydrogen cracking exist, e.g. under conditions of severe restraint, consideration shall be given to the benefits of either maintaining or boosting the pre-heat temperature for a minimum of two hours after the welding has been completed, or applying an intermediate post-weld heat treatment to facilitate hydrogen removal.

10.3.2.4 Where pre-heating is specified, welding, where practicable, shall be continued without interruption. If the continuity of the pre-heating is interrupted, the welding shall be discontinued and the joint shall be allowed to cool slowly by wrapping in a dry insulating blanket. The preheat shall be re-applied before further welding is commenced.

10.3.2.5 Austenitic steels do not require pre-heat for welding.

10.3.2.6 No welding or tack welding shall be carried out when the temperature of the parent metal within 150 mm of the joint is less than 5 °C.

### 10.3.3 Pre-heat for thermal cutting

Pre-heating temperatures for thermal cutting shall be determined by the manufacturer. Recommendations are given in table 10.3-1.

Table 10.3-1 — Recommended preheat temperatures for thermal cutting

Steel type	Steel group	Thickness mm	Minimum preheat temperature °C
Carbon C-Mn	1	≤ 150 > 150	Not required 50
0,3 Mo	1	< 30 ≤ 30	Not required 100
Various	2.1 and 4	< 15 ≤ 15	Not required 150
1 Cr ½ Mo	5.1	< 50 ≤ 50	Not required 150
2¼ Cr 1 Mo	5.2	< 50 ≤ 50	100 150
9 Cr 1 Mo	6	All	150
12 Cr 1 MoV	6	All	200
NOTE The above recommendations should be considered as a general guide to good practice. Other pre-heating temperatures are permitted.			

### 10.3.4 Measurement of pre-heat

10.3.4.1 The manufacturer shall implement procedures for the measurement and maintenance of the pre-heat temperature. Guidance is given in EN ISO 13916.

NOTE Acceptable methods of temperature measurement include temperature-indicating crayons and/or thermo-couples.

10.3.4.2 The pre-heat temperature shall be checked periodically during the period of application.

## 10.4 Post-weld heat treatment

### 10.4.1 General

10.4.1.1 The methods of post-weld heat treatment are given in 10.4.2 and post-weld heat treatment procedures are given in 10.4.3. Where, for practical reasons, it is necessary to adopt different methods or procedures, they shall be permitted when:

- the proposed methods or procedures are based on simulation tests on specimens of the material; or
- the methods or procedures are proven by other means as representing safe practice.

10.4.1.2 The equipment for heat treatment shall be suitable for the heat treatment in question. It shall enable the temperature within the component to be controlled with adequate accuracy and uniformity, especially for those materials which have a small permissible heat treatment temperature range.

10.4.1.3 Heat treatment records shall be provided which indicate the temperature, the method and rate of heating and cooling, and the holding time. Records shall also be available showing the temperature of martensitic transformation for materials of steel group 6.

10.4.1.4 Except in the cases covered by 8.8 and 9.4.1, post-weld heat treatment shall be carried out after all welding has been completed.

NOTE In selecting the temperature to be used for heat treatment, the criteria given in table 10.4-1 should be adopted.

Table 10.4-1 — Criteria for selecting the temperature

Method	Control temperature
Furnace heat treatment	Use the middle of the specified range.
Non-furnace heat treatment (resistance, induction, controlled flame etc.)	Use the upper end of the specified range.
Additional heat treatment (intermediate or repair)	Use the lower end of the specified range.

The time at temperature shall be measured from the time when the last thermocouple, reading the lowest temperature, reaches the minimum temperature of the specified range.

10.4.1.5 The temperature ranges and holding times used for post-weld heat treatment shall be to the ranges given in tables 10.4-2 and 10.4-3.

Table 10.4-2 — Temperature ranges for post-weld heat treatment for welded joints of similar and dissimilar materials

Steel type	Steel group	Temperature range °C										
		1	1	2.1	2.1	2.1	4 <sup>a</sup>	5.1	5.2	6 <sup>b</sup>	6 <sup>b</sup>	
C-Mn	1	550 – 600	550 – 600	550 – 600	550 – 600	550 – 600						
0,3 Mo	1	550 – 600	550 – 630	550 – 600	550 – 600	550 – 600		600 – 630				
Fine grained	2.1	550 – 600	550 – 600	550 – 600	550 – 600	570 – 600						
1 NiMoCuNb	2.1	550 – 600	550 – 600	570 – 600	570 – 600	570 – 620		600 – 620				
	4 <sup>a</sup>											
1 Cr ½ Mo	5.1		600 – 630			600 – 620		620 – 680	660 – 700			
2¼ Cr 1 Mo	5.2							660 – 700	680 – 730	730 – 760	730 – 760	710 – 730 <sup>c</sup>
9 Cr 1 Mo	6 <sup>b</sup>								710 – 730 <sup>c</sup>	730 – 760	740 – 780	740 – 770
12 Cr 1 MoV	6 <sup>c</sup>								730 – 760	710 – 730 <sup>c</sup>	740 – 770	730 – 770

To be determined by reference to the material specification.

These materials require transformation to martensite prior to pwht.

<sup>c</sup> Only for consumable of the type 2 ⚡ Cr 1 Mo.

NOTE 1 Other material combinations not covered by the table above, and variations from the temperatures given in the table above, may be acceptable, provided the manufacturer can ensure that, by their use, the safety of the boiler is not impaired.

NOTE 2 The post-weld heat temperature for ferritic austenitic joints between dissimilar materials shall be that required for the ferritic side of the joint.

EN 12952-5:2001 (E)

Table 10.4-3 — Holding time for post-weld heat treatment conditions for welded joints

Typical steel type	Steel group	Zone I			Zone II			Zone III		
		Min. specified weld thickness <i>c</i> mm	Min. holding time <i>t<sub>1</sub></i> minutes	Min. specified weld thickness <i>c</i> mm	Min. holding time / minutes	Min. specified weld thickness <i>c</i> mm	Min. holding time / minutes	Min. specified weld thickness <i>c</i> mm	Min. holding time / minutes	
C-Mn	1	$e < 35$	pwht not required	$35 \leq e \leq 90$	$t_2 = 1 \times e$	$e > 90$	$t_1 = 90 + 0,5 \times (e - 90)$			
0,3 Mo	1	$c < 35$	pwht not required	$35 \leq e \leq 90$	$t_2 = 1 \times e$	$e > 90$	$t_1 = 90 + 1 \times (e - 90)$			
Fine grained	2.1	$e < 35$	pwht not required	$35 \leq e \leq 60$	$t_2 = 2 \times e$	$e > 60$	$t_1 = 120 + 0,5 \times (e - 60)$			
1 NiMoCuNb	2.1	$c < 13$	$t_1 \gg 13$	$13 \leq e \leq 60$	$t_2 = 1 \times e$	$e > 60$	$t_1 = 60 + 0,5 \times (e - 60)$			
	4'									
1 Cr 1/2 Mo	5.1	$c < 13'$	$t_1 > 30$	$13 \leq e \leq 60$	$t_2 = 2 \times e$	$e > 60$	$t_1 = 120 + 1 \times (e - 60)$			
2 % Cr 1 Mo	5.2	$c < 13'$	$t_1 > 30$	$13 \leq e \leq 60$	$t_2 = 2 \times e$	$e > 60$	$t_3 = 120 + 1 \times (e - 60)$			
9 Cr 1 Mo	6	$c < 13$	$t_1 > 30$	$13 \leq e \leq 90$	$t_2 = 2,5 \times e$	$e > 90$	$t_1 = 225 + 1 \times (e - 90)$			
12 Cr 1 MoV	6	$c < 13$	$t_1 > 30$	$13 \leq e \leq 90$	$t_2 = 2,5 \times e$	$e > 90$	$t_3 = 225 + 0,5 \times (e - 90)$			

To be determined by reference to the material specification.

No post-weld heat treatment required on tube butt welds (W1) and attachment welds (W2) if all the following conditions are fulfilled.

– nominal diameter < 120 mm and nominal thickness < 13 mm.

No post-weld heat treatment required on tube butt welds (W1) and attachment welds (W2) if all the following conditions are fulfilled.

– design mean wall temperature  $\gg 480$  °C; nominal diameter < 120 mm and nominal thickness < 13 mm.

NOTE 1 The holding times to be used for joints of dissimilar materials shall be in accordance with the manufacturer's own proven procedure which shall ensure that, by their use, the safety of the boiler is not impaired.

NOTE 2 See figure 10.4-1 for example of applying this table.

key

a Minimum holding time /

b Minimum controlling weld thickness *c*

c see column 4

d  $t_1 = (1 \dots 2,5) \cdot r$  (see column 6)

e  $t_2 = t_2 + (0,5 \dots 1) (e - e_2)$  see

column 8

f Zone I

g Zone II

h Zone III

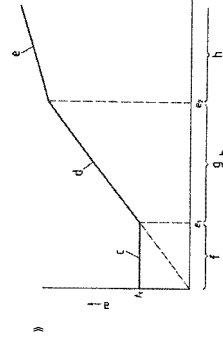

NOTE 1 To be read in conjunction with table 10.4-3.

NOTE 2 The controlling weld thickness is given in 10.4.1.6 and 10.4.1.7

Figure 10.4-1 — Examples of applying minimum holding times for different controlling weld thicknesses

10.4.1.6 Where the component contains welded joints connecting parts which differ in thickness, the controlling thickness to be used in determining the requirements for post-weld heat treatment times shall be as given in table 10.4-4.

Table 10.4-4 — Controlling thickness for different jointtypes

Joint type	Controlling thickness
Butt welds (W1)	The thickness of the thinner part at the welded joint.
Fillet welds (W2)	The specified throat thickness of the weld.
Set-on branch (W3)	The thickness of the branch at the joint.
Set-in or set-through branch (W4)	The thickness of the shell at the joint.
See figure 10.4-2 for examples of W1, W2, W3 and W4.	

When the component to be post-weld heat treated contains welds with different individual controlling thicknesses, the governing thickness to be used to determine the overall post-weld heat treatment shall be the greater of the individual controlling thicknesses.

10.4.1.7 When weld repairs or modifications have been made to a component after the final post-weld heat treatment stage, except as in the case covered by 8.8, further heat treatment shall be carried out in accordance with the requirements of 10.4. The controlling thickness to be used in defining the time required at temperature shall be one of the following:

- a) the depth of the weld repair (W5);
- b) the throat thickness of the weld where additional welds are added for modification purposes, see 10.4.1.6;
- c) the thickness of the additional weld runs where reinforcement is added (W6).

See figure 10.4-2 for examples of W5 and W6.

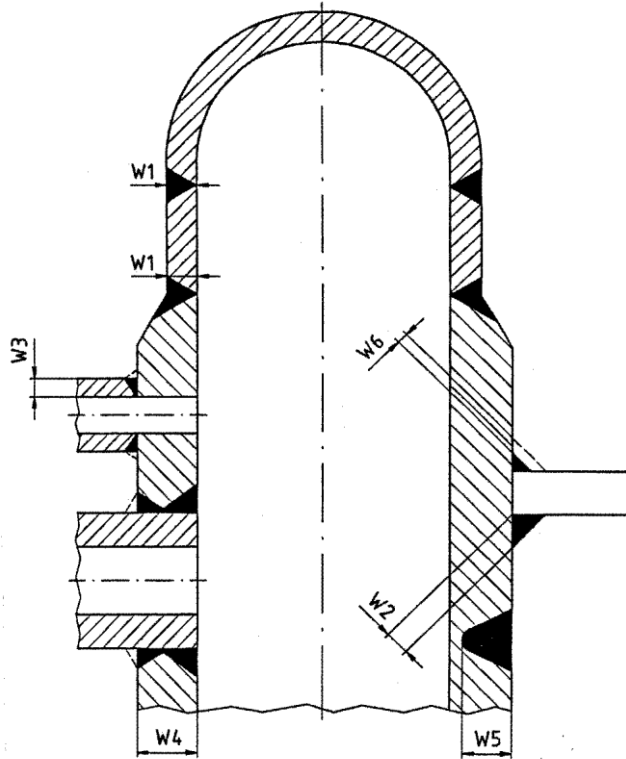

NOTE Dimensional and temperature limitations on application when post-weld heat treatments are not required are given in table 10.4-2

Figure 10.4-2 — Typical examples of controlling thicknesses

10.4.1.8 Intermediate heat treatment shall be implemented at the manufacturer's discretion to facilitate fabrication. The duration of such intermediate heat treatment shall be decided by the manufacturer but the temperatures employed shall not exceed those given in table 10.4-1. Temperatures and times of intermediate heat treatment shall be recorded.

10.4.1.9 Existing welding procedure approvals, which were based on national standards, shall not require re-qualification with respect to heat treatment, provided the procedure used for any heat treatment falls within the times and temperatures specified in tables 10.4-1 and 10.4-2.

## 10.4.2 Methods of post-weld heat treatment

10.4.2.1 Wherever possible, the component should be heat treated as a whole in an enclosed furnace heated by gas or by electricity. Where this is impracticable, it is permissible to adopt the methods described in 10.4.2.2 to 10.4.2.5 (see also figure 10.4-3).

10.4.2.2 It is permissible to heat treat sections of the completed component in an enclosed furnace, providing the overlap of the previously heat treated sections is at least 1500 mm or  $5 \times \sqrt{r_{is} e_s}$ , whichever is the greater, where  $r_{is}$  is the internal radius of the component and  $e_s$  is the nominal thickness at the weld.

Where this method is used, the portion outside the furnace shall be shielded so that the longitudinal temperature gradient is such that the distance between the peak and half-peak temperatures is not less than  $2,5 \times \sqrt{r_{is} e_s}$ .

10.4.2.3 It is permissible to locally heat treat circumferential seams by heating an insulated band around the entire circumference of the component. The width of the heated band shall not be less than  $5 \times \sqrt{r_{is} e_s}$ , the weld being in the centre.

Where the circumferential weld to be heat treated is between component strakes and a dished or hemispherical end, the whole of the end shall be included in the heated band. The heated band width on the component course side shall be at least  $2,5 \times \sqrt{r_{is} e_s}$ .

Sufficient insulation shall be fitted to ensure that the temperature of the weld and its heat affected zone is not less than that specified and that the temperature at a distance of  $2,5 \times \sqrt{r_{is} e_s}$  from the centre line of the weld is not less than the half-peak temperature. In addition, the adjacent portion of the component outside the heated zone shall be thermally insulated such that the temperature gradient is not harmful.

NOTE A minimum total insulated band width of  $10 \times \sqrt{r_{is} e_s}$  is recommended for the purpose of complying with this requirement.

10.4.2.4 Where tubes or fittings are subsequently butt welded to branches or stubs on a shell, and post-weld heat treatment is required according to 10.4.1, it is permissible to locally post-weld heat treat the butt welds by heating insulated bands around the component as shown in figure 10.4-3. The disposition of the heating elements and insulation around the butt weld shall be such as to produce a temperature profile which is approximately symmetrical about the weld and circumferentially uniform.

EN 12952-5:2001 (E)

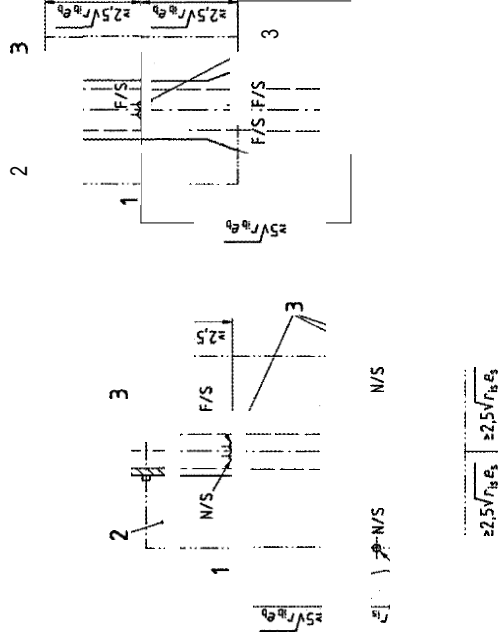

key

1 site weld

2 heated zone

3 thermocouples

NOTE Minimum requirements are one near side (N/S) and one far side (F/S) per position as indicated.

Figure 10.4-3 — Minimum heated band widths for local heat treatment

Where the attaching butt weld is at a distance not less than  $5 \times \sqrt{r_{ib} e_b}$  from the branch/stub to shell weld it may be post-weld heat treated in isolation (see figure 10.4-3 right side). Where the attaching butt weld is at a distance less than  $5 \times \sqrt{r_{ib} e_b}$  from the branch/stub to shell weld the post-weld heat treatment shall be applied simultaneously to the butt weld and the branch/stub to shell weld as shown in figure 10.4-3 at left side.

The temperatures measured at a distance of not less than  $2,5 \times \sqrt{r_{ib} e_b}$  from the centreline of the butt weld, or  $2,5 \times \sqrt{r_{is} e_s}$  from the outside surface of the branch/stub axis where appropriate, shall not be less than one-half the specified temperature measured at the butt weld.

Care shall be taken during welding and post-weld heat treatment of the butt weld to ensure harmful temperature gradients do not occur local to the weld between the shell and the branch/stub.

10.4.2.5 When a component is heat treated by internal means it shall be fully encased with thermal insulating material.

#### 10.4.3 Post-weld heat treatment procedures

10.4.3.1 During the heating and holding periods, the furnace atmosphere shall be such as to avoid excessive oxidation of the surface of the component. There shall be no direct impingement of flame on the surface of the component.

10.4.3.2 During the heating and cooling stages on drums and headers in the range up to and including 500 °C, variations in temperature throughout the component shall not exceed 150 °C within a distance of 4 500 mm, and any temperature gradient shall be gradual. Above 500 °C temperature variations shall not exceed 100 °C.

10.4.3.3 In the case of furnace post-weld heat treatment of ferritic steels, the temperature of the furnace at the time when the component is placed into or taken out of the furnace shall not exceed:

- a) 400 °C – for components of less than 60 mm thickness and not complex in shape;
- b) 300 °C – for components of 60 mm thickness and over, or of complex shape.

The furnace heating and cooling rate up to or down from the component temperatures specified in table 10.4-2 shall not exceed:

- c) 220 °C/h – for component thicknesses  $e \leq 25$  mm;
- d)  $5\ 500/e$  °C/h – for component thicknesses within the range  $25\ \text{mm} < e \leq 100$  mm;
- e) 55 °C/h – for component thicknesses  $e > 100$  mm.

where  $e$  is the nominal thickness of the component in mm.

10.4.3.4 The temperature specified shall be the actual temperature of any part or zone of the component being heat treated and shall be measured normally at the outside surface by thermocouples in effective contact with the component and protected from heat transfer to/from surroundings in order to ensure a true temperature measurement.

Welds attaching thermocouples to components shall be ground flush after heat treatment has been completed.

NOTE Where a furnace charge comprises a number of similar components, the thermocoupling may be to one component provided it can be demonstrated that the temperature distribution within the furnace is uniform.

EN 12952-5:2001 (E)

A sufficient number of temperatures shall be recorded continuously and automatically. Several thermocouples shall be applied to ensure that the whole component or zone being heat treated is within the range specified.

The manufacturer shall demonstrate that the thermocouples and temperature recording instrumentation are accurate over the temperature range covered by the heat treatment, or such equipment shall be included in an approved calibration programme.

An automatic temperature/time record of the heat treatment of each component shall be available for inspection and shall be retained as a record.

#### 10.5 Heat treatment of production test plates

Test plates provided in accordance with clause 8 of EN 12952-6 shall be subjected to the same heat treatment conditions after welding as that applied to the shell or drum they represent.

NOTE Test plates may be heat treated independent of the drum they represent.

## Annex A (normative)

## Tube bending procedure tests

## A.1 General

A.1.1 The requirements to be met by procedure tests covering the bending and forming of tubular components, as defined in 7.3.2 are given in the following clauses. Procedure tests for tubular products are divided into three groups, depending on outside diameter and the forming processes employed, as follows:

- A.2 Hot or cold formed bends in tubes with outside diameter  $\leq 142$  mm
- A.3 Cold formed bends in tubes with outside diameter  $> 142$  mm
- A.4 Hot formed bends in tubes with outside diameter  $> 142$  mm

A.1.2 Procedure tests carried out within the material groups defined in table A.1 of EN 12952-2 qualify other lower alloyed or softer materials (lower ultimate tensile strength) in the same group, in particular materials in steel group 1.2 cover 1.1 and 5.2 cover 5.1.

A.1.3 The validity ranges of the tube bending procedure tests are defined in A.2.3, A.3.3 and A.3.4.

A.1.4 Procedure test bends shall be bent to an angle of at least 90°. This shall be deemed to represent the minimum requirements for all bend angles. The thickness and DFC measurements shall be taken at 30° intervals from within this bend angle. Thickness determination shall normally be by sectioning but, for tubes above 80 mm nominal outside diameter, thickness may be determined by ultrasonic means. Any mechanical test specimens required shall, where possible, be taken from within this bend angle. However, where this is not possible, required specimens shall be taken from the straight tube adjacent to the commencement of the bend, which has been subject to the same heat treatment, if any, as the bend.

A.1.5 The manufacturer shall prepare documented records of all tube bend procedure tests.

A.2 Hot or cold formed bends in tubes with outside diameter  $\leq 142$  mm

## A.2.1 Types of bending processes

The bending process is normally characterised by specific machines using different forms of tooling. A change to a similar machine, of different load capacity, using the same tooling shall not require requalification.

The following shall be permitted types of tube bending processes, but these are not to be considered as limiting:

- rotary draw bend (without mandrel);
- rotary draw bend (with mandrel);
- boost bending (without mandrel);
- boost bending (with mandrel);
- press or squeeze bending;
- roll bending;
- any of the above in conjunction with local automatic strip heating on the intrados of the bend;
- gang bending for water wall panels.

Other than for local automatic strip heating on the intrados of the bend, where hot bending is employed, heating shall be by an induction process or by heating in a gas fired or other form of furnace/muffle.

#### A.2.2 Post-bending heat treatment (PBHT)

Bends shall be subject to PBHT in accordance with 7.3.8 and 7.3.9 prior to testing.

Separate qualification shall be required for:

- a) cold bend (without PBHT);
- b) cold bend (with PBHT);
- c) hot bend (without PBHT);
- d) hot bend (with PBHT).

Any test bends made using controlled local automatic strip heating on the intrados of the bend, except those in steel group 1.1 and 1.2, shall be normalised, or normalised and tempered, as appropriate, in accordance with the requirements of the base material specification or data sheet.

#### A.2.3 Validity range of tests

A.2.3.1 Any combinations of tube outside diameter, wall thickness and bend radius for a given material grouping (see A.1.2) and given types of bending process shall be acceptable, provided the requirements for the tube forming ratio (TFR) given in A.2.3.2 are met.

A.2.3.2 The TFR shall be determined by a particular set of bending test parameters  $d_o$ ,  $e$  and  $r_b$  in accordance with A.2.3.3. Any other combination of parameters, within a given steel group and bending process up to a TFR of 110% of the one determined in the test, shall be covered.

A.2.3.3 TFR shall be:

$$T_{FR} = \frac{d_o^2}{e \times r_b} \quad (A.1)$$

where

$d_o$  = tube outside diameter, in mm;

$e$  = nominal tube wall thickness, in mm;

$r_b$  = radius of bend measured to the centre-line of the tube, in mm.

The following example illustrates how TFR shall be applied:

Dimensions of test bend:

Outside diameter of tube  $d_o$  51

Nominal tube thickness  $e$  5

Radius of bend  $r_b$  150

Steel group: 1

Bending process: Cold rotary draw.

$$T_{FR} = \frac{d_0^2}{e \times r_b} = \frac{51^2}{5 \times 150} = 3,468 \quad \text{validity range: } 3,468 \times 110 \% = 3,815$$

Other tube bends made with the same bending process in the same steel group would be compared for qualification within the validity range of the test bend in accordance with table A.2-1:

Table A.2-1 — Validity range for different bends

$d_0$	$e$	$r_b$	TFR	Within Validity Range
44,5	4	133	3,772	Yes
44,5	5	133	2,978	Yes
51	4	150	4,335	No – New qualification required
51	6	200	2,168	Yes
63,5	5	190	4,244	No – New qualification required
63,5	8	150	3,360	Yes
70	6	210	3,889	No – New qualification required
70	8	250	2,450	Yes
76,1	7	228	3,628	Yes
76,1	8	190	3,810	Yes

#### A.2.4 Qualification test requirements

##### A.2.4.1 General

A procedure test bend shall be produced on the nominated bending machine and shall be subject to the relevant PBHT.

The following data shall be determined and shall be reported.

##### A.2.4.2 Ripples on intrados of the bend

The intrados of the bend shall be examined visually, if any ripples are detected they shall conform to the requirements of 7.3.10.

##### A.2.4.3 Surface defects

The outer surface of the bend shall be examined and shall be shown to conform to the requirements of 7.3.11.

Visual examination shall be applicable to all material groups. In addition, steel groups 2 and 6 shall be examined for transverse defects on the outside diameter of the bend by means of magnetic particle inspection to EN 1290. For steel conforming to steel group 8, dye penetrant inspection to EN 571-1 shall be used in place of magnetic particle inspection.

##### A.2.4.4 Bend geometry

The tube bend geometry shall conform to the requirements given in 7.3.4, 7.3.5 and 7.3.7.

##### A.2.4.5 Hardness tests

For hot formed bends, or bends requiring post-bending heat treatment, the hardness at the extrados of the bend shall be measured after completion of the heating process. The hardness measured shall be not more than 80 HV 10 higher than the hardness of the un-deformed material.

EN 12952-5:2001 (E)

#### A.2.4.6 Mechanical tests

All hot formed bends, or bends requiring post-bend heat treatment other than stress relieving, shall be sectioned to provide mechanical tests, as follows:

- tensile test at room temperature in accordance with EN 10002-1;
- Charpy V-notch tests (if so required by the base material standard) in accordance with EN 10045-1.

NOTE The specimens should be taken from within the bend except as permitted by A.1.4.

The number and position of the specimens shall be as specified for the base material. The resulting values shall be in accordance with the relevant base material standard or data sheet.

#### A.2.4.7 Gang bending of tube panels

The tube bends produced by the gang bending method shall comply, in all respects, with the requirements of tubes bent singularly.

The gang bending method shall be qualified by a tube bending procedure test which is valid for the specific gang bending machine being utilised. The tube panel used in the test shall consist of at least three tubes which have been welded together prior to gang bending.

### A.3 Cold formed bends in tubes with outside diameter > 142 mm

#### A.3.1 Types of bending processes

The bending process is normally characterised by specific machines using different forms of tooling. A change to a similar machine, of different load capacity, using the same tooling shall not require requalification.

#### A.3.2 Post bending heat treatment (PBHT)

Bends shall be subject to PBHT in accordance with 7.3.8 and 7.3.9 prior to testing.

Separate qualification shall be required for:

- a) cold bend (without PBHT);
- b) cold bend (with PBHT).

#### A.3.3 The validity range of the test

The test carried out shall also cover a range of tube bending parameters above and below those tested.

The range for diameter and thickness shall be as follows:

- Tested outside diameter  $d_o$  covers diameters within the range  $0,5 \times d_o$  to  $1,8 \times d_o$ ;
- Tested thickness  $e$  covers thicknesses within the range  $0,7 \times e$  to  $1,5 \times e$ .

The tube bending ratio  $r_b/d_o$  used during the test shall cover all higher bending ratios as follows:

Test ratio  $r_b/d_o$  of 1,8 covers  $r_b/d_o$  of 2,0;  $r_b/d_o$  of 2,5 .....etc.

where  $r_b$  is the radius of the bend which has been tested.

### A.3.4 Qualification test requirements

#### A.3.4.1 General

A procedure test bend shall be produced on the nominated bending machine and shall be subject to any relevant PBHT.

The following data shall be determined and shall be reported.

#### A.3.4.2 Ripples on intrados of the bend

The intrados of the bend shall be examined visually. If any ripples are detected, they shall conform to the requirements of 7.3.10.

#### A.3.4.3 Surface defects

The outer surface of the bend shall be examined and shall be shown to conform to the requirements of 7.3.11.

Visual examination shall be applicable to all material groups. In addition, steel groups 2 and 6 shall be examined for transverse defects on the outside diameter of the bend by means of magnetic particle inspection according to EN 1290. For steel conforming to steel group 8, dye penetrant inspection according to EN 571-1 shall be used in place of magnetic particle inspection.

#### A.3.4.4 Bend geometry

The tube bend geometry shall conform to the requirements of 7.3.6 and 7.3.7.

Measurements for DFC shall be taken at 30° intervals around the bend. Wall thickness measurement may be performed by using an ultrasonic technique.

#### A.3.4.5 Hardness test

For cold formed bends which require post-bending heat treatment, the hardness at the extrados of the bend shall be measured after completion of the heating process. The hardness measured shall not be more than 80 HV 10 higher than the hardness of the un-deformed material.

#### A.3.4.6 Mechanical testing

Cold formed bends which require post-bend heat treatment other than stress relieving, shall be sectioned to provide mechanical tests, as follows:

- tensile test at room temperature in accordance with EN 10002-1;
- Charpy V-notch tests (if so required by the base material standard) in accordance with to EN 10045-1.

The number and position of the specimens shall be as specified for the base material. The resulting values shall be in accordance with the relevant base material standard or data sheet.

## A.4 Hot formed bends in tubes with outside diameter > 142 mm

### A.4.1 Types of bending processes

The bending process is normally characterised by specific machines using different forms of tooling. A change to a similar machine, of different load capacity, using the same tooling shall not require requalification.

EN 12952-5:2001 (E)

#### A.4.2 Post-bending heat treatment (PBHT)

Bends shall be subject to PBHT in accordance with 7.3.8 and 7.3.9 prior to testing.

Separate qualification shall be required for:

- a) heating by an induction processes;
- b) heating by gas or other forms of furnace/muffle.

#### A.4.3 The validity range of the test

The test carried out shall also cover a range of tube parameters above and below those tested.

The range for diameter and thickness shall be as follows:

- Tested outside diameter  $d_o$  covers diameters within the range  $0,5 \times d_o$  to  $1,8 \times d_o$ .
- Tested thickness  $e$  covers thicknesses within the range  $0,7 \times e$  to  $1,5 \times e$ .

The tube bending ratio  $r_b/d_o$  used during the test shall cover all higher bending ratios as follows:

- Test ratio  $r_b/d_o$  of 1,8 covers  $r_b/d_o$  of 2,0;  $r_b/d_o$  of 2,5 ..... etc.

where  $r_b$  is the radius of the bend tested.

#### A.4.4 Qualification test requirements

##### A.4.4.1 General

A procedure test bend shall be produced by the nominated process and shall be subject to the specified PBHT.

The following data shall be determined and shall be reported.

##### A.4.4.2 Ripples on intrados of the bend

The intrados of the bend shall be examined visually. If any ripples are detected they shall conform to the requirements of 7.3.10.

##### A.4.4.3 Surface defects

The outer surface of the bend shall be examined and shall be shown to conform to the requirements of 7.3.11.

Visual examination shall be applicable to all material groups. In addition, steel groups 2 and 6 shall be examined for transverse defects on the outside diameter of the bend by means of magnetic particle inspection according to EN 1290. For steel conforming to steel group 8, dye penetrant inspection according to EN 571-1 shall be used in place of magnetic particle inspection.

##### A.4.4.4 Bend geometry

The tube bend geometry shall conform to the requirements of 7.3.6 and 7.3.7.

Measurements for deviation from circularity shall be taken at 30° intervals around the bend. Wall thickness measurement may be performed by using an ultrasonic technique.

#### A.4.4.5 Mechanical testing

##### A.4.4.5.1 General

The test bend shall be sectioned to provide the following test specimens. Their results of the tests shall be recorded.

##### A.4.4.5.2 Metallographic examination

Longitudinal microsections shall be taken from the un-deformed section of the tube and from the bend centre for evaluation by optical microscopy up to  $\times 1\,000$ . A single sample shall be prepared from the straight material and samples taken from the intrados and extrados of the bend.

No cavities or structural abnormalities shall be permitted.

##### A.4.4.5.3 Charpy V-notch impact tests (for thicknesses $e > 15$ mm) in accordance with EN 10045-1

###### A.4.4.5.3.1 Definitive tests

Test conditions:

- a) Straight tube, transverse Charpy V-notch specimens; Notch vertical to the surface, test temperature: RT or 0 °C (as for base material specification) close to the surface, figure A.4-1, position 6, one set of three specimens.
- b) Bend centre, transverse Charpy V-notch specimens; Notch vertical to the surface, test temperature: RT or 0 °C (as for base material specification) close to the surface, figure A.4-2 position 4 and position 5, one set of three in each position.

The minimum value shall be in accordance with the requirements of the base material specification or data sheet.

###### A.4.4.5.3.2 Comparative tests

If the results of the test obtained under A.4.4.5.3.1 are inconsistent, comparative tests, below, shall be carried out.

These tests shall be carried out at 100 °C in order to reduce the scatter of the impact energy values. The values are for comparing the test results taken from the bend with those of the straight portion of the tube and are not for determining absolute values for the material.

Test conditions:

- a) Straight tube, longitudinal Charpy V-notch specimens; Notch in parallel with the surface, close to the surface, test temperature: 100 °C, figure A.4-1, position 1, one set of three specimens.
- b) Bend centre, longitudinal Charpy V-notch specimens; Notch in parallel with the surface, close to the surface, test temperature: 100 °C, figure A.4-2, position 2 and position 3, one set of three specimens from each position.

The difference between the mean values of positions 2 and 3 shall not be greater than 30 % of the value at position 1.

##### A.4.4.5.4 Tensile test in accordance with EN 10002-1

Transverse tensile test specimens shall be taken in straight tube, figure A.4-1, position 7 and in the centre of the bend, position 8 and position 9, as shown in figure A.4-2 (test temperature RT).

The results of the test shall conform to the material specification or data sheet.

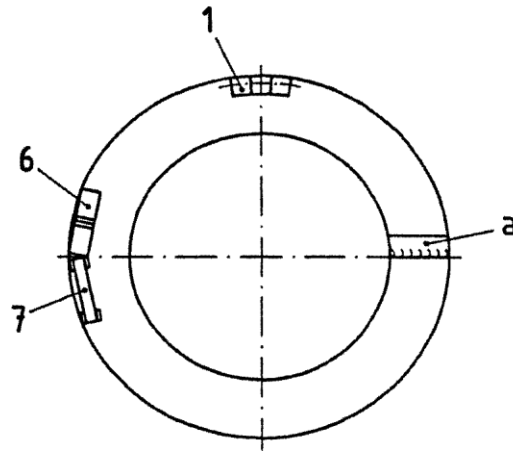

key  
a see A.4.4.5.3

Figure A.4-1 — Specimens from straight portion of the tube

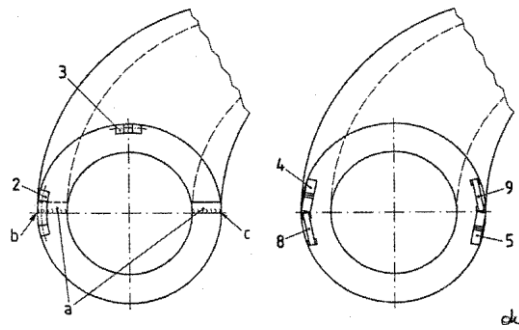

key  
a see A.4.4.5.3  
b Tension zone  
c Compression zone

Figure A.4-2 — Specimens from bent portion of tube

## Annex B (informative)

### Welded pressure connections and non-pressure containing attachments

The welded connections and attachments included in prEN 1708-1, prEN 1708-2, EN 29629 and EN ISO 9692-2 which are appropriate for water-tube boilers, together with the notes included therein, are considered to provide adequate guidance for water-tube boiler application when supplemented by the figures B-1, B-2 included in this annex.

For examples of connections for the welding of unstayed flat ends see 10.3 of EN 12952-3.

The purpose of this annex, in conjunction with prEN 1708-1, prEN 1708-2, EN 29629 and EN ISO 9692-2 is to exemplify commonly accepted welded connections in water-tube boilers. The recommendations are to be used for guidance purposes and are not intended to promote standardization of connections that may be regarded as mandatory or to restrict development in any way.

The manufacturer is responsible for the interpretation of the details for application to his own designs based on his past experience and good engineering practice. In selecting the appropriate detail to use for each type of connection from the several alternatives shown in this annex, prEN 1708-1, EN 1708-2, EN 29629 and EN ISO 9692-2 consideration should be given to the service conditions under which it will be required to function. The weld dimensions shown in the various figures are based on common engineering practice, and it will be necessary in each case for the manufacturer to ascertain the connections selected are of adequate strength and are suitable for the welding process used.

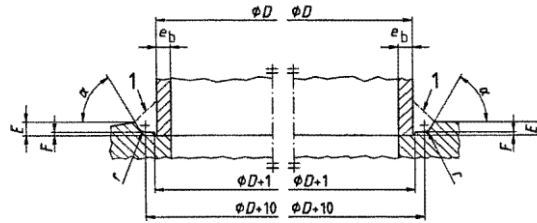

key

- E = 6 mm
- F = 1,5 mm
- r = 3 mm
- a = 60°

1 Profile to meet design requirements

a) For tubes or nozzles up to approximately 100 mm bore and 6 mm wall thickness  $e_b$

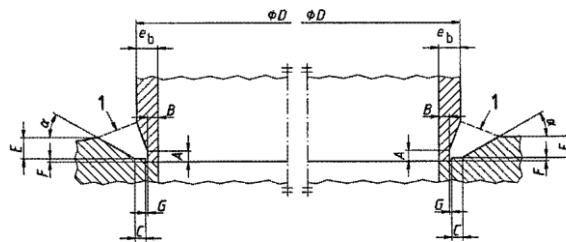

key

- A = 5 mm
- B = 5 mm
- C = 5 mm
- E =  $e_b$
- F = 1,5 mm
- G = 0,5 mm
- a = 30°

1 Profile to meet design requirements

b) For tubes or nozzles up to and including 150 mm bore and wall thickness  $e_b$  over 6 mm and up to and including 13 mm

Figure B-1 — Examples of tube or nozzle to header connections (continued)

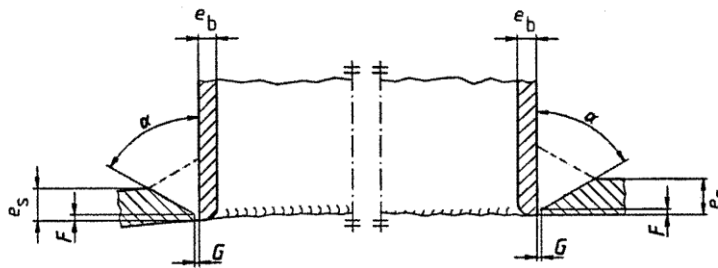

key  
 $F = 2 \text{ mm}$   
 $G = 1,5/2,0 \text{ mm}$   
 $e_s = 16 \text{ mm max.}$   
 $\alpha = 60^\circ$

c) For all tube and nozzle sizes

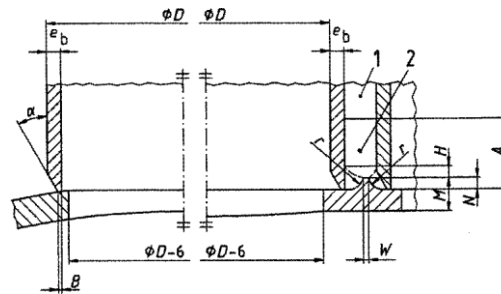

key  
 $A = 30 \text{ mm}$   
 $B = 1,5 \text{ mm}$   
 $H \checkmark 3 \text{ mm}$   
 $M \checkmark 10 \text{ mm}$   
 $N = 5 \text{ mm}$   
 $W \checkmark 2 \text{ mm}$   
 $r = 6 \text{ mm}$   
 $\alpha = 30^\circ$

1 Fin material  
 2 Weld access hole (filled after welding tube to header)

d) Tube panel connections only applicable to tubes up to 100 mm bore and 6 mm wall thickness  $e_b$

Figure B-1 — Examples of tube or nozzle to header connections (concluded)

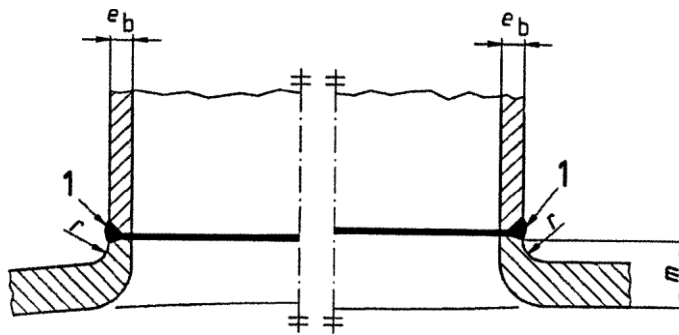

key

1 Conventional butt joint

$e_b$  is wall thickness of tube

$m$  should be as large as possible but in no case less than  $2 \times e_b$

$r$  should be not less than  $e_b$  with a minimum of 6 mm

Figure B-2 — Example of tube to extruded opening connection

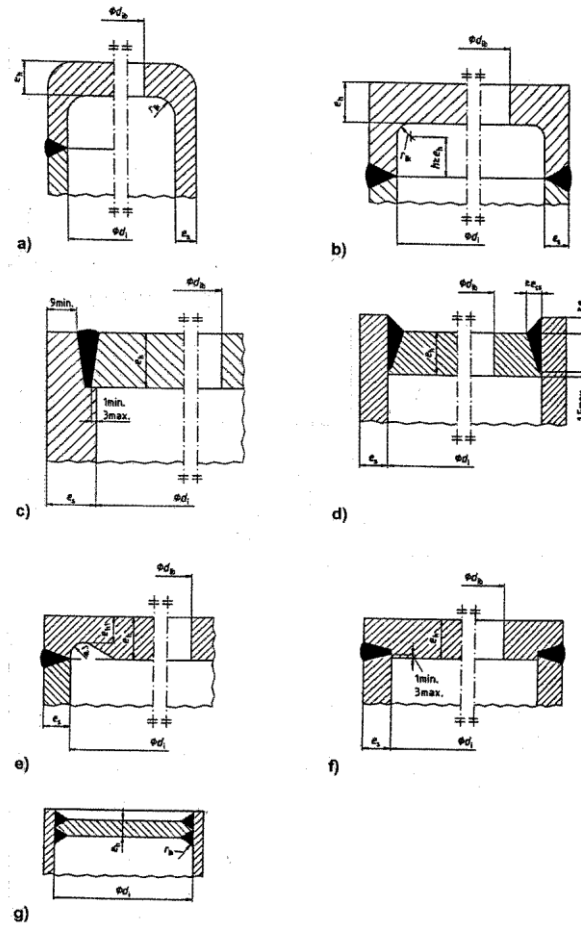

NOTE 1 For requirements and limitations see 10.3 of Part 3 of this standard.

NOTE 2 Figure a) is not applicable to welding.

Figure B-3: Examples of connections for the welding of flat ends

## Annex C (normative)

### Manufacture of welded tubewalls

#### C.1 General

These requirements apply to the manufacture of various types of gas-tight welded tubewalls commonly used in boiler construction.

#### C.2 Methods of manufacture

##### C.2.1 General

The manufacturing processes commonly used are given below. These cover the fabrication of tubewall panels by use of welding, and involve the joining of fins to tubes, or fins to fins.

##### C.2.2 Tubes finned by welding

Two basic methods shall be adopted as follows:

- the welding of tubes together by the insertion of a fin (bar steel) between them. The closure welds are between the edges of the fin and the adjacent tubes, see figures C-1a), C-1b) and C-1c);
- individual fins (bar steel), of half the fin space width welded to each tube to form a series of finned tubes. The closure welds are between the edges of the abutting fins, see figure C-1d).

##### C.2.3 Integrally finned tubes

The closure welds shall be between the edges of the abutting fins, see figure C-1e).

Such tubing shall be supplied directly by the tube manufacturer. It is available with the fins having been produced by a rolling or an extrusion process. The finned tube shall be subjected to an acceptance test generally in accordance with EN 10216-2. Additionally, further testing shall be required to ensure that fin twisting, centreline deviation and off-set are contained within the limits set by the manufacturer, to ensure that dimensional requirements and weld quality can be achieved.

##### C.2.4 Other methods

Other types of construction may be employed provided they shall be shown to meet the requirements of C.5 and C.6.

#### C.3 Allowable materials

##### C.3.1 Tubes

Tubes used for tubewall construction shall be supplied in accordance with the requirements of EN 12952-3.

##### C.3.2 Fins

Fins shall be made from plate, flat rolled wire or bar steel. Suitable non-alloy steels shall be in accordance with EN 10025 e.g. S235 JR and S275 JR. Low-alloy steels shall be in accordance with EN 10028-2. Other steels may be used in accordance with the manufacturer's own proven procedures which shall ensure that, by their use, the safety of the boiler is not impaired.

### C.3.3 Filler metals

The filler metal used shall be compatible with the tube and fin materials and shall satisfy the requirements of EN 12952-3. For tubewalls to be used at elevated temperatures, the filler metal shall be of the same type as the tubing, or shall conform to the nearest lower alloy consistent with the type of material to be welded.

## C.4 Manufacturing processes and controls

### C.4.1 Welding processes

The selection of the welding processes used shall be at the discretion of the manufacturer and shall be depend on the material, tube dimensions, manufacturing process and the welding conditions involved.

Acceptable welding processes include, for example:

- Manual metal arc using covered electrodes;
- Gas shielded metal arc;
- Submerged arc;
- Tungsten inert gas.

### C.4.2 Specific requirements for manufacture

#### C.4.2.1 Surface cleanliness

In order to obtain a satisfactory connection between the tube and the fin it is necessary for the surface of the tube and fin, within the welding zone, to be cleaned to a level suitable for the welding process to be used.

#### C.4.2.2 Fin to tube attachment welds

##### a) Un-penetrated tube wall thickness $e_r$

The weld penetration shall be such as to leave either

- 1) a minimum of 2 mm of un-penetrated tube wall thickness  $e_r$ , which may be achieved by the pre-selection of an appropriate tube wall thickness or
- 2) an un-penetrated wall thickness of less than 2 mm, but not less than the minimum calculated thickness given in 11.3 of EN 12952-3. In this case, post-weld heat treatment shall be applied in accordance with the requirements of tables 10.4-1 and 10.4-2.

##### b) Weld attachment of the fin to tube

Partial penetration welds shall be permitted. The tube to fin welded joints, of the types shown in figures C-1a) to C-1d) inclusive, shall be such as to ensure adequate heat transfer from the fin into the tube wall. For the welding processes listed in C.4.1, this condition shall be considered to be satisfied, if the values indicated in figure C-2 at the partial penetration weld are achieved.

EN 12952-5:2001 (E)

#### C.4.2.3 Welding imperfections in fin to tube welds

The limits for welding imperfections shall be in accordance with table C-1.

#### C.4.2.4 Site welding

The panel sections of tubewalls shall be manufactured in such a manner that the site-welded joint between adjacent panel sides is made by a continuous longitudinal weld between fin edges. Any site welding directly to the tube surface shall be limited to the small areas of make-up fin local to the tube butt welds between panel ends.

#### C.4.3 Heat treatment

##### C.4.3.1 Pre-heating

Where pre-heating is required, it shall be carried out in accordance with 10.3.

##### C.4.3.2 Post-weld heat treatment

Where post-weld heat treatment is required, it shall be carried out in accordance with tables 10.4-1 and 10.4-2.

#### C.5 Welding procedure approvals

A welding procedure approval test shall be performed, by the production of a test panel consisting of not less than three tubes, to demonstrate that the welding is in accordance with the requirements of EN 288-8 and the geometry and weld quality are in accordance with the requirements of this annex.

#### C.6 Production tests

Prior to the commencement of a production run<sup>1)</sup>, a production test shall be performed to demonstrate compliance with the requirements given in figures C-2, C-3 and C-4.

Any significant changes in welding parameters or equipment occurring during a production run shall be sufficient cause to require an additional production test.

#### C.7 Non-destructive examination (NDE)

NDE shall be limited to 100 % visual examination of all fin to tube welding.

---

<sup>1)</sup> A production run is a series of tubes of the same size and material being welded to form a panel on a specific machine within the same machine set-up.

Table C-1 — Limits for weld imperfections in fin to tube welds

Identification of imperfection			Maximum permitted	
EN 26520 Group No.	EN 26520 Defect No.	Type of imperfection	EN 25817 level <sup>a</sup>	Definition of maximum permitted
1	100	Cracks (all)	B	Not permitted
2	200	Cavities (all)	"S"	When occurring at the surface, – diameter $\leq$ 2 mm, with the additional condition that:  – it does not occur at a stop or restart
3	301X 302X 3031 304X	Slag inclusions (all) Flux inclusions (all) Oxide inclusions Metallic inclusions (all)	"S"	Not permitted when occurring at the surface (shall be removed by grinding for example)  Local oxide layers due to GTAW or GMAW are not defined as inclusions and are acceptable.
4	401X	Lack of fusion (all)	B	Not permitted in the fusion welds, but see C.4.2.2.
5	5011 5012	Undercut	B	Depth $\leq$ 0,5 mm (whatever the length is), a smooth transition is required
5	503	Excessive convexity	"S"	Weld shape should not be more than 30° convex; see figure C-4
5	507	Misalignment	"S"	6 $\leq$ 2 mm, see figure C-3a
5	508	Angular misalignment	"S"	6 $\leq$ 3 mm, see figure C-3b
5	510	Burn through	"S"	Not permitted. Unmelted remaining wall required:  $\leq$ 2 mm; see C.4.2.2a)
5	517	Poor restart	B	Not permitted
6	601	Stray flash or arc strike	"S"	Not permitted, grinding is required plus DPI or MPI to ensure that no crack is left
6	602	Spatter	"S"	Shall normally be removed; isolated spatter may however be permitted
6	604	Grinding mark	"S"	Not permitted; shall be flushed by grinding; a smooth transition is required
6	605	Chipping mark	"S"	Not permitted; shall be flushed by grinding; a smooth transition is required
6	606	Underflushing	"S"	Not permitted; minimum wall thickness required by design

<sup>a</sup> The requirements of this standard have been supplemented to reflect current European boiler manufacturing practice. Where this has been done an identifying letter "S" has been utilized in the table.

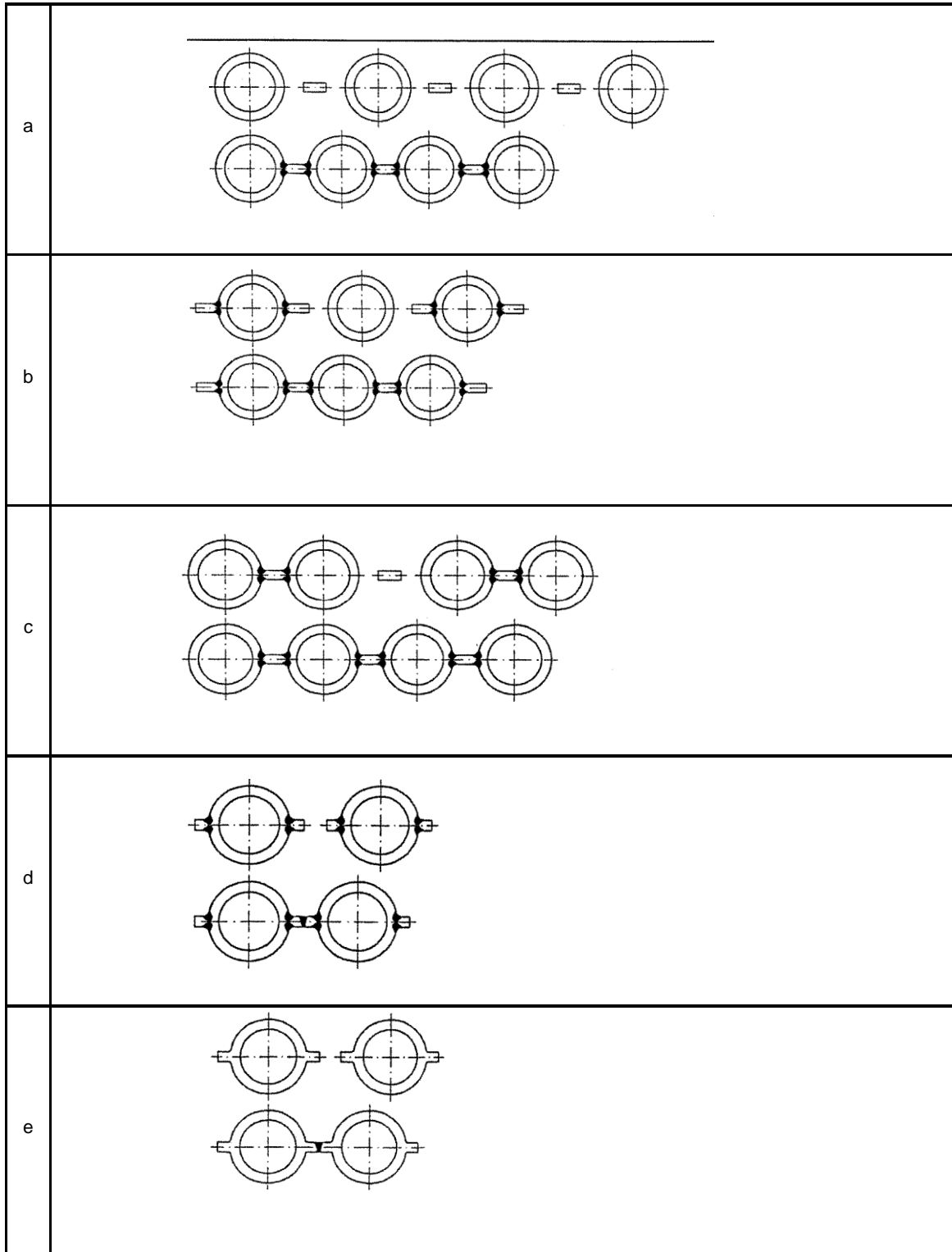
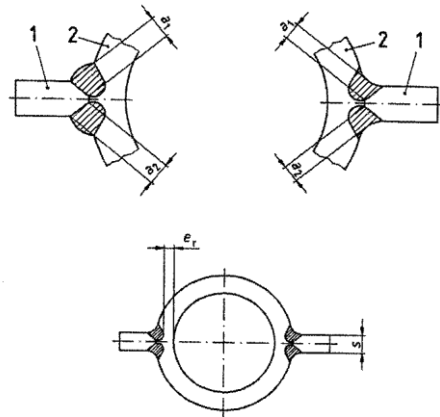

Figure C-1 — Examples of tubewall construction



key  
 $e_r \checkmark 2 \text{ mm}$ ;  
 $a_1 + a_2 \checkmark s$

see C.4.2.2 a)

1 Tube  
 2 Fin

Figure C-2 — Weld requirements for fin to tube welds

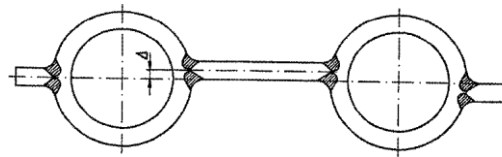

key  
 $6 \checkmark 2 \text{ mm}$

a) Linear misalignment

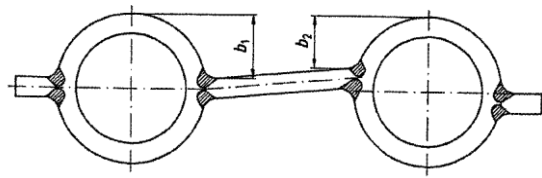

key  
 $b_1 - b_2 = 6 \checkmark 3 \text{ mm}$

b) Angular misalignment

Figure C-3 — Allowable misalignment for fin to tube welds

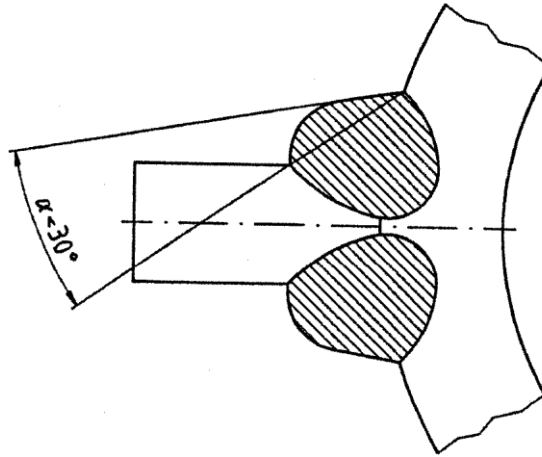

Figure C-4 — Allowable excessive convexity for fin to tube welds

## Annex D (normative)

## Coiled boilers and coiled superheaters

## D.1 General

This annex gives the special requirements applicable to the design, manufacture and inspection of coiled boilers and coiled superheaters. Except for these special requirements, all the requirements of this European Standard shall apply.

## D.2 Special requirements

Circumferential butt welds in the coiled length of the tubing shall be acceptable, subject to the following conditions:

- a) The  $r_b/d_o$  ratio should preferably be not less than 6  
 where  $r_b$  is the mean radius of the coil;  
 and  $d_o$  is the nominal outside diameter of the tube.
- b) The maximum departure from circularity of the tube diameter in the bent condition shall not exceed 5 %;
- c) Backing rings shall not be used with the butt welds;
- d) the oxy-acetylene welding process shall not be used.

For coils constructed from steel group 1.1, 1.2 or austenitic steels, where the  $r_b/d_o$  ratio is less than 6, or for other steels of any  $r_b/d_o$  ratio, the ability to bend the tube without detrimental effect on the weld metal shall be demonstrated. This shall be by means of a welding procedure approval test involving the butt welding of a coil then bending to the minimum  $r_b/d_o$  ratio to be used in production for a given thickness of tube and then subjecting the test weld to destructive and non-destructive tests. The nature of the tests carried out in this procedure test shall be in accordance with the manufacturer's own proven procedures which shall ensure that, by their use, the safety of the boiler is not impaired.

## Annex E (normative)

### Chemical recovery boilers

#### E.1 General

This annex gives special requirements applicable to the specific rules for workmanship and construction of chemical recovery boilers (black liquor boilers) as defined in E.2. These special requirements are additional to all the other requirements of this European Standard which shall continue to apply.

#### E.2 Definition

The chemical recovery boiler is primarily a pulping chemical recovery process unit where the organic materials are burned while the recovered chemicals are reduced and drained as molten smelt from the furnace bottom. The heat released is used for steam generation.

#### E.3 Special requirements for forming of composite tube bends

##### E.3.1 General

The general rules of EN 12952-5, mainly 7.3 and annex A, shall be supplemented by application of the specific rules in E.3.2.

##### E.3.2 Application of forming rules to composite tubing

###### E.3.2.1 Range of tube bending procedure test approval

Only an approval obtained with composite tubes shall be valid for forming composite tubes. When calculating a tube forming ratio (TFR), the nominal tube wall thickness  $e$  shall be the total nominal wall thickness of a composite tube. The tube outside diameter  $d_o$  shall be the total nominal diameter of a composite tube. A bending procedure test shall cover only that material combination including also the base material/cladding thickness relation of the composite tube it represents.

###### E.3.2.2 Additional tests required for composite tubes

###### E.3.2.2.1 Ultrasonic testing of a composite tube bend concerning the metallurgical bonding

A tube bend shall be tested for the total length of the bend with ultrasonic inspection in accordance with C.2.7.1 of EN 12952-2. Acceptance criteria shall be the same as in C.2.7.1.3 of EN 12952-2.

###### E.3.2.2.2 Hardness test

In hardness tests in accordance with A.2.4.5, the hardness shall be measured from a macro specimen at the extrados of both materials.

###### E.3.2.2.3 Macro examination

The macrosections shall be taken from the longitudinal bend centre plane. Any cavities or structural abnormalities, specially on the bonding, shall not be permitted.

## E.4 Special requirements for manufacture of welded tubewalls from composite tubes

### E.4.1 General

The general rules in annex C shall be supplemented by the specific rules in E.4.2.

### E.4.2 Fins

Fins for composite tubing shall be made from a plain austenitic or ferritic steel plate or strip. Fins can also be made from a composite plate or strip.

### E.4.3 Fin-to-tube attachment welds on composite tubes

Fin welds shall not penetrate essentially below the surface of the ferritic pressure retaining inner core material. Unpenetrated minimum calculation thickness shall always be maintained.

## E.5 Material marking

Marking method in accordance with C.2.3.1 of EN 12952-2 shall be allowed for austenitic or composite tubes.

## E.6 Flash butt welding

Water containing tubes or composite tubes in chemical recovery boilers where leak could result in smelt-water explosion shall not be welded by flash welding. It is, however, permitted to use flash welding for superheater tubes of these boilers provided that the manufacturer can show that the welds do not increase any risk to safe operation of the boiler.

## Annex F (informative)

### Guidelines for the determination of the competency of boiler manufacturers

#### F.1 General

The basis of this European Standard is that a manufacturer of a boiler should ensure that the requirements of the specification for the boiler are competently executed in the design and subsequent manufacturing operations. The guidelines contained in this annex identify criteria whereby a judgement can be made as to the competency of a boiler manufacturer's organisation and controls.

The principles of EN ISO 9001 and EN 729-2 have been utilised as a basis for forming this judgment and the information requested provides guidance on the potential competency of a manufacturer and his available controls.

The guidelines include criteria embracing design, materials, fabrication, erection commissioning, examination and inspections.

#### F.2 Responsibility of the purchaser

It is the responsibility of boiler purchaser (owner, user or operator) to place the order for boiler plant with a competent boiler manufacturer to ensure that adequate quality is obtained when the boiler is put in operation in accordance with the manufacturer instructions. The guidelines indicate how such a judgement may be made by the boiler purchaser if he so requires.

#### F.3 Responsibility of the manufacturer

It is the responsibility of the boiler manufacturer to ensure that the requirements of the specification are competently executed by applying appropriate techniques and relevant procedures during all stages of the design, manufacture and subsequent commissioning of a boiler and to ensure that all work performed complies with the applicable requirements of this European Standard.

It is permitted for parts of the work in a contract, such as design, forming, welding, heat treatment, non-destructive testing etc. to be subcontracted by the manufacturer responsible for the overall boiler plant. It is then the responsibility of the manufacturer to place the order for such work with a competent subcontractor or part manufacturer.

The offices, workshops and sites associated with design and manufacture (see EN 12952-3 and EN 12952-5) should be properly equipped and have suitable provisions for all the inspections and testing specified in EN 12952-6. Manufacturing and other procedures should be adequate and manufacturing and testing personnel and equipments should be competent and properly qualified for their assigned tasks. Reference should be made to EN 729-2 for additional guidance.

#### F.4 Requirements concerning manufacturer's competency

This annex F provides guidelines as to how judgement can be made regarding the competency of a manufacturer and the manufacturer should confirm that he can meet all the requirements of this European Standard.

Basic requirements are given in EN ISO 9001 or EN ISO 9002 and EN 729-2 and EN 729-3.

Specific requirements are contained in EN 12952-3, EN 12952-4 and EN 12952-6.

Table F-1 provides a cross reference between the quality elements and processes concerned and the source of the requirements.

In some cases, in order to provide an overall picture of the manufacturing operation, additional data are requested concerning plant capacity and personnel involved etc.

#### F.5 Manufacturer's competency declaration

The "Manufacturer's competency declaration" (table F-2) has been designed to enable a manufacturer to be able to assess that he has made appropriate provisions for all the requirements of this European Standard. The form provides only the essential content of a declaration. If a sub-contractor or manufacturer of a part of a boiler is only providing limited components, processes or services, the declaration may be modified to suit the particular circumstances. It can therefore be enlarged or shortened to properly reflect the operations to be provided.

The manufacturer having overall responsibility for the boiler, sub-contractors and those providing services should ensure that an up to date, completed form (see table F-2), is available to any involved or authorized persons at the boiler manufacturer's office. The completed forms should be available over the total period of manufacturing up to the take over of the boiler.

Table F-1 — Schedule concerning topics for competency declaration of boiler manufacturers

No.	Topic/Q-element	Matter/process	Criteria
1	Manufacturer		
1.10		general information	info
1.2		activities/responsibilities	info
1.3		typical products/service	info
1.4		references to previous works	info
2	Quality system		
2.1		quality manual/certification	
2.2		authorizations	
3	Organisation		
3.1		management managing director QM representative auth. welding coordinator authorized NDE coordinator inspection department head	EN ISO 9001/4.1.2 EN ISO 9001/4.1 EN ISO 9001/4.1.2.3 EN 729-2/6.3; EN 719 EN 719 EN 719 Tab. 1/1.8
3.2		staff	EN ISO 9001/4.4; info
4	Design		
4.1		R+D activities chemical laboratories materials technology lab. process engineering lab.	EN ISO 9001/4.4.2 info info info
4.2		design design staff CAD-equipments procedures design review for welding	EN ISO 9001/4.4 info info info EN 729-2/4.3
4.3		commissioning staff procedures for service instructions	info
5	Purchasing		
5.1		staff	info
5.2		subcontractors approval of subcontractors list of main subcontractors	EN ISO 9001/4.6.2 EN ISO 9001/4.6.2 (c)
5.3		control of subcontr. material purchasing data. verification of purchased products	EN ISO 9001/4.6 EN ISO 9001/4.6.3; EN 729-2/5 EN ISO 9001/4.6.4/4.10.2
6	Manufacturing		
6.1		shop location	info
6.2		transport facilities from workshop	info

Table F-1 (continued)

No.	Topic/Q-element	Matter/process	Criteria
6.3	Manufacturing (continued)	materials normally employed	info
6.4		product forms normally employed	info
6.5		machines/equipments list of equipments – strakes, ends – tubes, pipes hot forming – strakes, ends – tubes, pipes machining/cutting gang bending of membrane walls bending of composite tubes mechanical tube connections	EN 729-2/8.2 EN 12952-5/7.2 EN 12952-5/7.3  EN 12952-5/7.2 EN 12952-5/7.3 info capacity EN 12952-5/7.1 EN 12952-5/7.3.12 EN 12952-5/7.3.13 EN 12952-5/9.4
6.6		heat treatment	
6.7		welding processes welding equipments storage of welding consumables	3.1.2 info info EN 729-2/10.3; EN 12952-5/8.2
6.8		procedure specifications procedure qualifications	EN 729-2/9.2; EN 12952-5/8.1.3 EN 729-2/9.3; EN 12952-5/8.3.1
6.9		welding staff qualification of personnel – welding coordinators – welders, operators	EN 729-2/6.3 EN 729-2/6.2
6.10		surface preparation/cleaning coating	info info
7	Site erection		
7.1		erection procedures	info
7.2		permanent staff	EN 12952-5/8, info
7.3		lifting equipments	info
7.4		PWHT-equipments	EN 729-2/12; EN 12952-5/10.4
8	Examination		
8.1		staff for workshop and site	
8.2		equipments: – material testing – NDE	EN 729-2/13.4
8.3		inspection/transfer of marking receiving inspection in-process inspection final inspection transfer of marking procedure for test equipment calibration	EN ISO 9001/4.16; EN ISO 9001/4.10.2 EN ISO 9001/4.10.3 EN ISO 9001/4.10.4  EN ISO 9001/4.11
8.4		inspection bodies	
9	Other		info

Table F-2 — Manufacturer's competency declaration form

Company's Logo		Manufacturer's competency declaration		Doc. No.	
Company's Name				Page	1 of 6
This declaration of competency complies with Annex F of EN 12952-5 "Guidelines for determination of the competency of boiler manufacturers"					
1	Manufacturer	Offices	Workshops		
1.1	General:	Adress: City: Telefon: Fax:	Adress: City: Telefon: Fax:		
1.2	Common activities/responsibilities		<input type="checkbox"/> full responsibility for boiler/component <input type="checkbox"/> limited responsibility boiler/component <input type="checkbox"/> basic design <input type="checkbox"/> detail design <input type="checkbox"/> manufacture <input type="checkbox"/> site erection		
1.3	Typical products/services supplied:				
1.4	References to previous works:				
2	Quality system				
2.1	Quality manual	Quality management system acc. to EN ISO 9001 <input type="checkbox"/> or EN ISO 9002 <input type="checkbox"/>			
		Edition of manual:			
		Certified by:			
		Scope of certification:			
		No./date of certificate:			
2.2	Other qualification/authorizations:				
		<input type="checkbox"/>			
		<input type="checkbox"/>			
		<input type="checkbox"/>			

Table F-2 (continued)

Company's Logo		<b>Manufacturer's competency declaration</b>		Doc. No.	
Company's Name				Page	2 of 6
3	Organisation				
3.1	Management	Function: Managing director(s): Quality management representative: Engineering department head: Manufacturing department head: Erection department head: Authorized welding coordinator: Authorized NDE coordinator: Inspection department head:	Names:		
3.2	Staff	Organisation: Design office: Production: Site erection (permanent): Quality department (including inspection and testing):	No. of employees:		
4	Design				
4.1	Research and development	Laboratories for analysis of: <input type="checkbox"/> fuel <input type="checkbox"/> ash <input type="checkbox"/> water <input type="checkbox"/> materials technology <input type="checkbox"/> process engineering			
4.2	Design				
	Design staff	engineers:	quantity:		
		draftsmen:	quantity:		
	CAD-equipments available:	Type/number:			
	Procedures available for:	<input type="checkbox"/> combustion calculation <input type="checkbox"/> flow calculation <input type="checkbox"/> heat transfer calculation <input type="checkbox"/> dimensioning calculation (code calculation) <input type="checkbox"/> fatigue analysis <input type="checkbox"/> stress analysis <input type="checkbox"/> finite element analysis <input type="checkbox"/> preparation of general arrangement drawings <input type="checkbox"/> preparation of work shop drawings <input type="checkbox"/> design review of drawings for welding			

Licensed Copy: sheffieldun sheffieldun, na, Sat Oct 28 06:34:42 GMT+00:00 2006, Uncontrolled Copy, (c) BSI

Table F-2 (continued)

Company's Logo		Manufacturer's competency declaration			Doc. No.	
Company's Name					Page	3 of 6
4.3	Commissioning	Number of employees (permanent): Procedures available for preparation of service instructions: <input type="checkbox"/> yes <input type="checkbox"/> no				
5	Purchasing					
5.1	Staff	Number of employees:				
5.2	Subcontractors	Approval:	procedure available: <input type="checkbox"/> yes <input type="checkbox"/> no			
		Main subcontractors:	list available <input type="checkbox"/> yes <input type="checkbox"/> no			
5.3	Control of subcontracted material	procedure for purchasing data and verification of products available <input type="checkbox"/> yes <input type="checkbox"/> no				
6	Manufacturing					
6.1	Location:	Shop	LengthxWidth m	Major crane (No./tons)	Hook height m	
6.2	Transport facilities from workshop Maximum component size:  Maximum component weight:  Transport limitations: (lorry, rail, ship)					
6.3	Materials normally employed:					
6.4	Product forms normally employed:		(dimensional range; tube diameter where applicable)			
6.5	Machines/Equipments		Quantity: Type: Machining			
	Cutting Cold forming Hot forming Tube gang bending machine for membrane walls					

Table F-2 (continued)

Company's Logo		Manufacturer's competency declaration		Doc. No.	
Company's Name				Page	4 of 6
6.6	Heat treatment (HT)				
	HT processes used: <input type="checkbox"/> Normalizing/solution annealing <input type="checkbox"/> Normalizing plus tempering <input type="checkbox"/> Quenching plus tempering <input type="checkbox"/> Postweld heat treatment				
	HT furnace/equipment	Size	Max. temperature °C	Heating methode (gas, inductive, resistance)	
6.7	Welding				
	Processes in accordance with EN 287-1, EN 1418 No. (see EN ISO 4063)	Designation		Approximate no. of approved welders or welding operators	
	111	Manual metal-arc welding with covered electrodes			
	121	Submerged arc welding with wire electrode			
	131	Metal-arc inert gas welding (MIG)			
	135	Metal-arc active gas welding (MAG)			
	136	Flux-cored wire metal-arc welding with active gas shielding			
	141	Tungsten inert gas arc welding (TIG)			
	311	Oxy-acetylene welding			
	24	Flash welding			
	781	Arc stud welding			
		Others			
Welding equipments			Quantity:	Type/capacity (amps):	
Welding sets:					
Rectifiers:					
Transformers:					
Membrane wall welding equipments:					
Submerged arc equipments:					
Orbital welding equipments:					
Flash welding equipments:					
Arc stud welding equipments:					
Others:					
Electrode storage and handling:					
Storage in controlled areas:			<input type="checkbox"/> yes	<input type="checkbox"/> no	
Baking ovens:			Qty.: .....	Max. temp.: ..... °C;	
Storage ovens:			Qty.: .....		
Quivers:			Qty.: .....		

Licensed Copy: sheffieldun sheffieldun, na, Sat Oct 28 06:34:42 GMT+00:00 2006, Uncontrolled Copy, (c) BSI

Table F-2 (continued)

Company's Logo		Manufacturer's competency declaration		Doc. No.		
Company's Name				Page	5 of 6	
6.8	Welding procedure specifications including approvals	Approx. no.:				
		List of WPS available:	<input type="checkbox"/>	yes	<input type="checkbox"/>	no
6.9	Welding staff:	List of welders available:				
			<input type="checkbox"/>	yes	<input type="checkbox"/>	no
	Quantity:					
	Welding coordinators:					
	Welding technicians:					
	Welding specialists:					
	Manual welders:					
	Welding operators:					
6.10	Surface preparation and coating:					
	Abrasive cleaning	Grades SA 1 to SA 3/... to ISO 8501-1	<input type="checkbox"/>	yes	<input type="checkbox"/>	no
		Automatic blast plant:	<input type="checkbox"/>	Manual blast plant:	<input type="checkbox"/>	
	Chemical cleaning	Pickling stainless steel:	<input type="checkbox"/>	Passivating:	<input type="checkbox"/>	
		Number and size of pickling tanks:				
	Coating application processes:					
		<input type="checkbox"/>	Brush/Roller			
		<input type="checkbox"/>	Airless spraying			
		<input type="checkbox"/>	Electrostatic spraying			
		<input type="checkbox"/>	Compressed air spraying			
	Check of coat thickness:	Measuring equipment (magnetic/inductive) available:				
		<input type="checkbox"/>	yes	<input type="checkbox"/>	no	
7	Site erection					
7.1	Erection procedures:	utilized	<input type="checkbox"/>	yes	<input type="checkbox"/>	no
7.2	Permanent staff:	Quantity:				
	Erection managers:					
	Erection supervisors:					
	Erection welding coordinators:					
	Erection NDE coordinators:					
	Welders/fitters:					
7.3	Lifting equipment:	(Type, quantity, capacity)				
7.4	PWHT-equipments:	(Type, quantity, control)				

Table F-2 (continued)

Company's Logo		Manufacturer's competency declaration		Doc. No.	
Company's Name				Page	6 of 6
8	Examination and inspection				
8.1	Staff:	Workshop	Site		
	Radiographers:				
	UT-examiner:				
	MT-/PT-examiners:				
	Inspectors:				
	Material testing examiners:				
8.2	Equipment:	Type	Quantity		
	for destructive tests:				
	for NDE:	X-ray:			
		Isotope:			
		UT:			
		MT:			
8.3	Inspections\transfer of marking:	common practice	performed by:		
			workshop	Q-department	
	receiving inspection	<input type="checkbox"/> yes <input type="checkbox"/> no	<input type="checkbox"/>	<input type="checkbox"/>	
	in-process inspection	<input type="checkbox"/> yes <input type="checkbox"/> no	<input type="checkbox"/>	<input type="checkbox"/>	
	final inspection	<input type="checkbox"/> yes <input type="checkbox"/> no	<input type="checkbox"/>	<input type="checkbox"/>	
	transfer of marking	<input type="checkbox"/> yes <input type="checkbox"/> no	<input type="checkbox"/>	<input type="checkbox"/>	
	Procedures available for calibration of test equipments:	<input type="checkbox"/> yes <input type="checkbox"/> no			
8.4	Inspection bodies Which inspection bodies inspections have you been involved with?				
9	Other Information:				
Date:		Manufacturer		(Stamp)	
Signature:					
Title:					

Licensed Copy: sheffieldun sheffieldun, na, Sat Oct 28 06:34:42 GMT+00:00 2006, Uncontrolled Copy, (c) BSI

## Annex ZA (informative)

## Clauses of this European Standard addressing essential safety requirements or other provisions of the Pressure Equipment Directive

This European standard has been prepared under a mandate given to CEN by the European Commission and the European Free Trade Association and supports essential safety requirements of the Pressure Equipment Directive 97/23/EC with regard to workmanship and construction requirements.

WARNING: Other requirements and other EU Directives may be applicable to the product(s) falling within the scope of this standard.

The following clauses of this standard given in table ZA-1 are likely to support requirements of the Pressure Equipment Directive 97/23/EC :

Table ZA-1 — Comparison between Pressure Equipment Directive 97/23/EC and EN 12952-5 with respect to workmanship and construction requirements for water-tube boilers

EN 12952-5 harmonized clauses	Content	Pressure Equipment Directive 97/23/EC Annex I
6.1 Annex A	Manufacturing procedures	3.1
7.1, 7.2, 7.3, 7.4	Preparation of component parts	3.1.1
7.1.2, 7.3.11, 8.4.1	Joining – Freedom from surface or internal defects	3.1.2 1st parag.
8.1.1, 8.7	Joining – Properties of joints	3.1.2 2nd parag.
8.1.3	Joining – Qualified personnel and suitable procedures	3.1.2 3rd parag.
8.3.2	Joining – Approval of welding personnel	3.1.2 4th parag.
7.3.8, 7.3.9, 8.6, 8.7, 10	Heat treatment	3.1.4
6.2, 6.3, 6.4	Traceability	3.1.5

Compliance with the clauses of this standard provides one means of conforming with the specific essential safety requirements of the Directive concerned and associated EFTA regulations.

## Bibliography

EN ISO 9000-1

Quality management and quality assurance standards – Part 1: Guidelines for selection and use  
(ISO 9000-1 : 1994)

EN ISO 9001

Quality systems – Model for quality assurance in design/development, production, installation and servicing  
(ISO 9001 : 1994)

EN ISO 9002

Quality systems – Model for quality assurance in production, installation and servicing (ISO 9002 : 1994)